



**International fibreboard  
case code**

**Code international pour  
emballage carton**

**Internationaler code für  
versandverpackungen**

**Codice internazionale per  
imballaggi in cartone ondulato**

**Código internacional para  
cajas de cartón ondulado**

**FEFCO**  
Corrugated Packaging



















# Código internacional para cajas de cartón ondulado

Este código ha sido desarrollado por FEFCO y ESBO, como sistema oficial, para sustituir largas y complicadas descripciones verbales de cajas de cartón ondulado y diseños, por símbolos sencillos de comprensión internacional, sin atender al lenguaje u otras diferencias.

Estas referencias pueden emplearse en pedidos y especificaciones de cajas de cartón ondulado para embalaje.

Sólo FEFCO y ESBO están autorizados hacer adiciones y modificaciones.

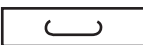
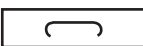
## Símbolos empleados en planos y sistemas informáticos

Símbolo dibujado	Código Ordenador	Descripción
<b>Cuts, scores, slits etc.</b>		
	CL	Contorno de cajas armadas o líneas de corte en plancha
	SC	Cortes ranurados
	CI	Líneas de hendido (plegado hacia el interior)
	CO	Líneas de hendido (plegado hacia el exterior)
	SI	Líneas de corte-hendido (plegado hacia el interior)
	SO	Líneas de corte-hendido (plegado hacia el exterior)
	DS	Líneas de doble hendido
	PL	Líneas de perforado
	SE	Líneas de corte intermitente
	TP	Perforación para desgarrar
<b>Junta de fabricación</b>		
	SJ	Grapada
	TJ	Encintada
	GJ	Encolada
<b>Aperturas</b>		
	PC	handholds stripped
	UC	Asas parcialmente recortadas
	NC	Asas parcialmente recortadas
<b>Dirección de la onda</b>		
	FD	Indicador de la dirección de la onda

## Los planos de los modelos de este código son siempre desde la perspectiva interior de la caja.

### Dimensiones de la caja

UAI menos que se indique lo contrario, todas las dimensiones se entienden como dimensiones internas en mm, y son como siguen:

Longitud (L) x Anchura (B) x Altura (H)

Longitud (L) = la dimensión mayor al abrir

Anchura (B) = la dimensión menor al abrir

Altura (H) = la dimensión desde la parte superior de la abertura hasta la base

Las dimensiones L, B, H se especifican en la descripción de cada modelo de caja. En algunos modelos, el valor numérico B puede ser mayor que el valor numérico L. Las mediciones deben realizarse bajo condiciones climáticas normalizadas, sobre planchas lisas y desde el centro del hendido, teniendo en cuenta el espesor del material.

Para cajas de tipo telescópico, la altura (h) de la parte superior (tapa) debe darse como una cuarta medida tras una barra inclinada, por ejemplo:

355 x 205 x 120/40 mm  
(L) (B) (H) (h)

Para cajas con solapas exteriores que monten, la longitud del área superpuesta (o) debe darse como una cuarta medida tras una barra inclinada, por ejemplo:

355 x 205 x 120/40 mm  
(L) (B) (H) (o)

### Dimensiones de la plancha

Al menos que se indique lo contrario, las dimensiones de la plancha de cartón ondulado se expresan en mm como sigue:

1º dimensión x 2ª dimensión

1º dimensión = paralela a las líneas de pegado

2ª dimensión = perpendicular a la líneas de pegado

### Versiones de un modelo

Algunos tipos de cajas pueden tener versiones derivadas sin necesidad de crear un nuevo modelo. En este caso se debe añadir un sufijo al número básico de modelo, separado por un guión.

Ejemplo: 0201-2.

Una versión puede ser única de un fabricante particular.

### Combinación de tipos

Los modelos mostrados son los tipos básicos de cajas de cartón ondulado. Si el diseño final es una combinación de dos o tres modelos básicos, por ejemplo en lo concerniente a la disposición de solapas, pueden describirse como sigue:

Solapas superiores como en 0204. Solapas inferiores como en 0215. Este modelo también puede ser descrito como 0204/0215 (solapas superiores/solapas inferiores).

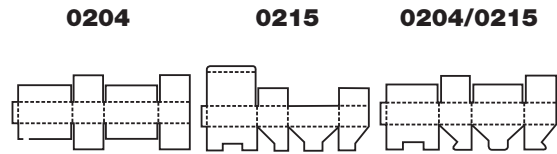

### Modelos y juntas de fabricación

Los planos de los desarrollos de los distintos modelos mostrados en este código, pueden necesitar modificaciones, dependiendo de la junta de fabricación elegida.

Algunos modelos pueden tener juntas de fabricación encolada, grapada o pegada con cinta. Una junta encolada o grapada puede ser tanto una extensión del panel corto como del largo.

Los ejemplos muestran cómo deberían indicarse éstas sobre un plano:

Ejemplo para todos los tipos

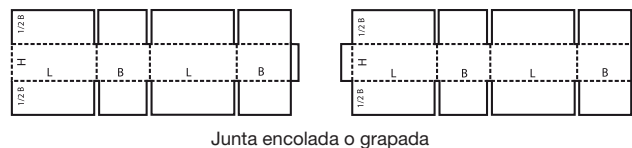
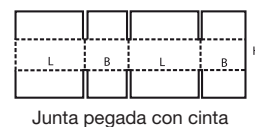
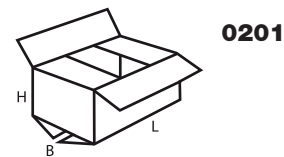

Esto es aplicable a todos los modelos de este código.

### Montaje manual o automático

Cada modelo incluye una de las siguientes indicaciones:

M – montaje manual normalmente

A - montaje automático normalmente

M/A – el montaje puede ser manual o automático

M+A – se requiere una combinación de ambos

Estas indicaciones se basan en la práctica corriente y pretenden dar una información adicional a fabricantes y usuarios.

Algunas cajas de montaje manual pueden cerrarse de forma automática (ejemplo : 0216 ó 0712)

# Descripción de los grupos de modelos básicos\*

Los términos caja, contenedor y embalaje son intercambiables en el contexto de estas descripciones.

## Consideraciones generales

Hay que tener en cuenta que algunos de los modelos de caja contenidos en el código bajo un número específico pueden también clasificarse en otros grupos de modelos básicos.

## 01 - Rollos y planchas comerciales

## 02 - Cajas de tipo ranurado

Cajas de tipo ranurado: consisten básicamente en una pieza con juntas de fabricación encolada, cosida o pegada con cinta y solapas superiores e inferiores. Se despachan extendidas en un plano, listas para su uso y se cierran utilizando las solapas superiores e inferiores.

## 03 Cajas telescópicas

Cajas telescópicas: fabricada con más de una pieza, se caracterizan por una tapa y/o fondo que se desliza sobre el cuerpo de la caja.

## 04 - Cajas plegables y bandejas

Cajas plegables y bandejas: son en general de una única pieza de cartón ondulado. El fondo de la caja se pliega para formar dos, o todas las paredes laterales, y la tapa. Pueden incorporarse al diseño elementos de cierre, asas, paneles expositores, etc.

## 05 - Cajas de tipo deslizante

Cajas de tipo deslizante: constan de varias piezas de forros interiores y fundas que deslizan en diferentes direcciones uno dentro de otro. Este grupo incluye también fundas exteriores para otras cajas.

## 06 - Cajas de tipo rígidas

Cajas de tipo rígidas: formadas por dos piezas separadas, para los extremos y un cuerpo; requieren un grapado u otra operación similar antes de que puedan utilizarse.

## 07 - Cajas de encolado rápido

Cajas de encolado rápido: están hechas generalmente de una sola pieza, se entregan extendidas en un plano o plegadas y listas para su utilización por medio de un sencillo montaje.

## 09 - Acondicionadores interiores

Acondicionadores interiores: como forros, refuerzos, casilleros, divisiones interiores, tanto si se ajustan a un modelo de caja o como piezas sueltas. El número de piezas de los acondicionadores interiores mostrados es arbitrario y puede aumentarse o disminuirse de acuerdo con las necesidades.

## Escritura de los modelos del código

Código completo: XXXX-XXXX	
Modelo	Versión
XXXX	-XXXX
Modelo/diseño estándar reconocido mediante este código	El número de versión para diferenciar las variaciones sobre el diseño estandarizado (corresponde a un diseño particular o del archivo CAD/CAM).

## Cierre de las cajas

Un cierre correcto y efectivo de las cajas es tan importante como su propia fabricación. Todos los métodos de cierre siguientes son posibles, tanto individualmente como combinados:

- encolado
- frío o caliente cinta
- automontaje
- grapado

### Cierre por medio de cinta

Puede realizarse de acuerdo con los ejemplos que se muestran

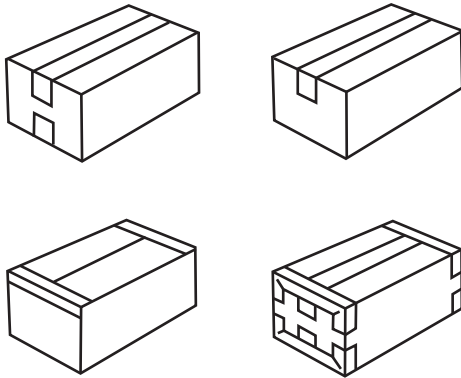

### Cierre por grapado

Puede realizarse de acuerdo con los ejemplos que se muestran



## Codificación de acondicionadores interiores

La siguiente gama de acondicionadores interiores se codifica de acuerdo al número de paneles empleados, en cualquier combinación de formas (para sistemas informáticos).

Número de paneles		CODE
2	>	0982
3	>	0983
4	>	0984
5	>	0985
6	>	0986
7	>	0987
8	>	0988
9	>	0989
10	>	0990
11	>	0991
12	>	0992
13	>	0993
14	>	0994
15	>	0995
16	>	0996
17	>	0997
18	>	0998
19	>	0999

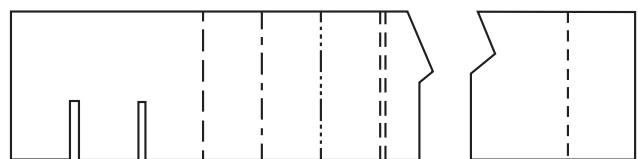

0982/0999  
M

# 0100

- ▲ **Commercial rolls and sheets**
- ▲ **Bobines, feuilles ou plaques commerciales.**
- ▲ **Handelsübliche Rollen und Tafeln**
- ▲ **Bobine e fogli pronti per vendita**
- ▲ **Rollos y planchas comerciales**

## 0100

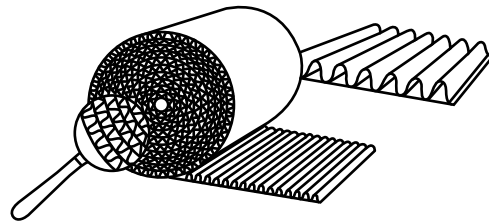

## 0110

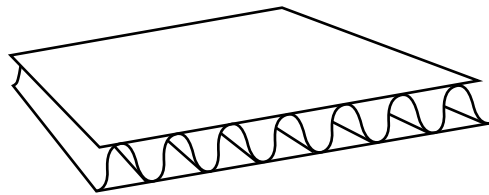

# 0200

- ▲ **Slotted-type boxes** consist of basically one piece with a glued, stitched or taped manufacturers joint and top and bottom flaps. They are shipped flat, ready to use and require closing using the flaps provided.
- ▲ **Caisses à rabats**, d'une seule pièce, avec joint d'assemblage collé, agrafé ou à bande gommée. Elles sont livrées à plat, prêtes à l'emploi et nécessitent d'être fermées.
- ▲ **Faltschachteln (Faltkisten)** bestehen in der Regel aus einem Stück mit einer durch Laschenklebung, Drahtheftung bzw. Klebestreifen verbundenen Fabrikante sowie Deckel- und Bodenklappen. Sie werden flach zusammengefasst versandt, sind

gebrauchsfertig und werden anhand der Klappen verschlossen.

- ▲ **Case a falde**: Scatole americane costruite in un singolo pezzo base con la giunta incollata, cucita o nastrata e con falde superiori e inferiori. Sono consegnate stese, pronte da utilizzare e richiedono chiusura tramite le apposite falde.
- ▲ **Cajas de tipo ranurado**: consisten básicamente en una pieza con juntas de fabricación encolada, cosida o pegada con cinta y solapas superiores e inferiores. Se despachan extendidas en un plano, listas para su uso y se cierran utilizando las solapas superiores e inferiores.

## 0200 M/A

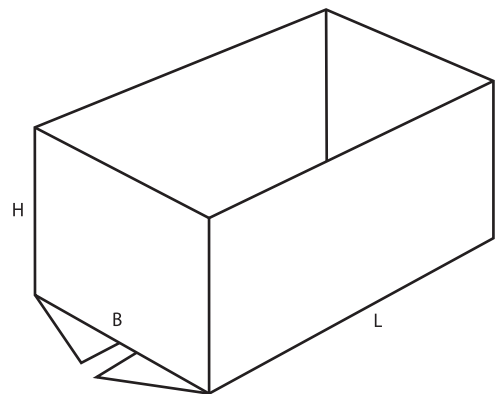
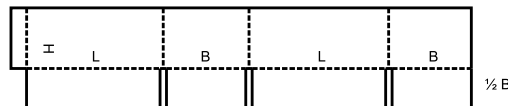

## 0201 M/A

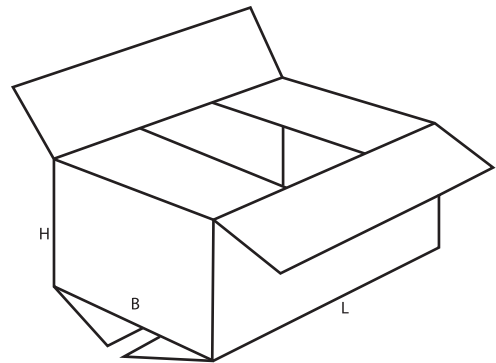
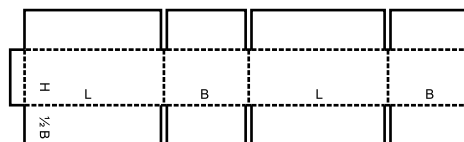

## 0202 M/A

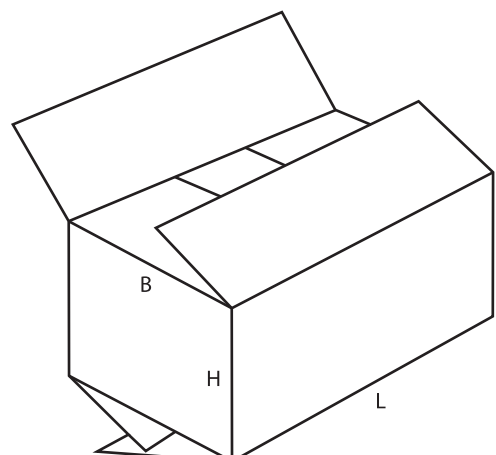
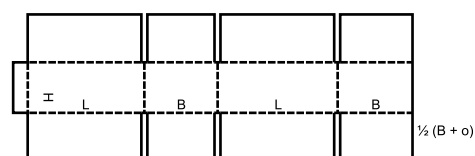

**0203 M/A**

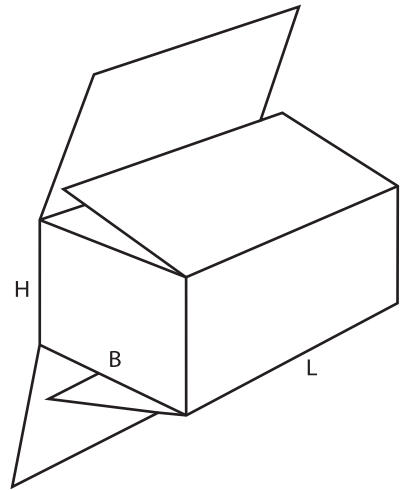
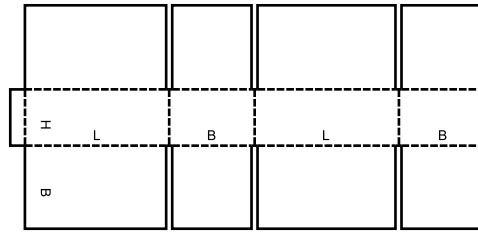

**0204 M/A**

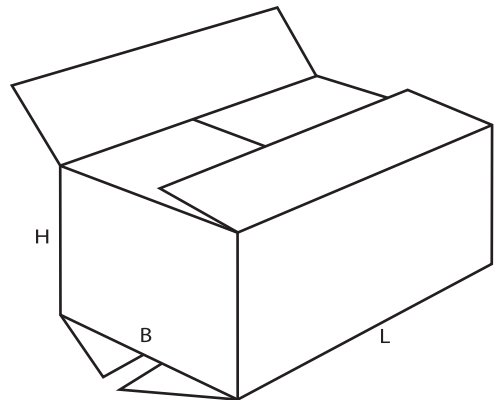
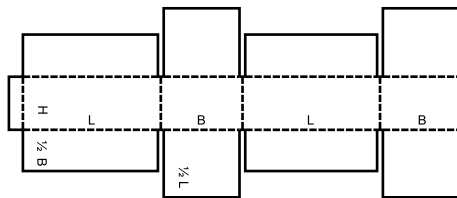

**0205 M/A**

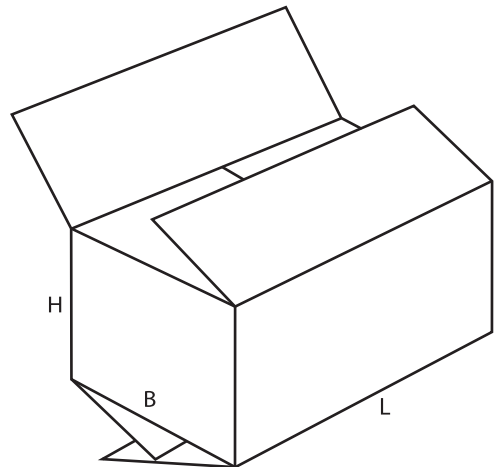
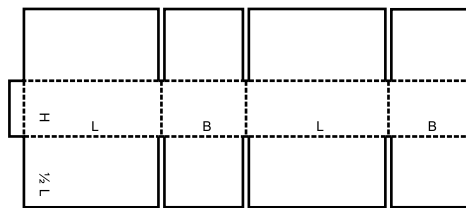

**0206 M/A**

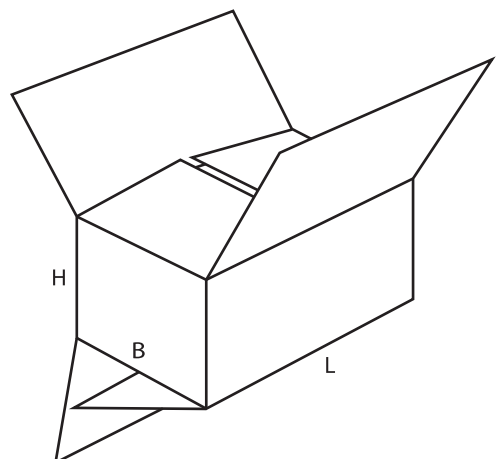
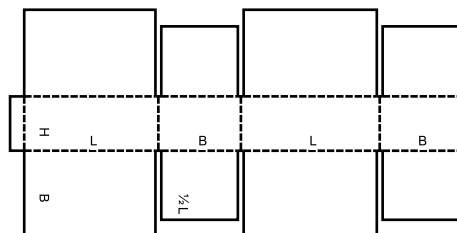

**0207 M**

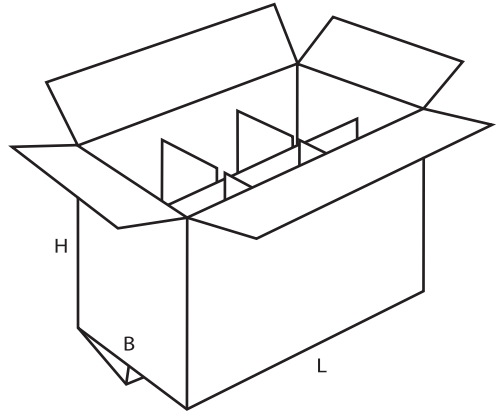
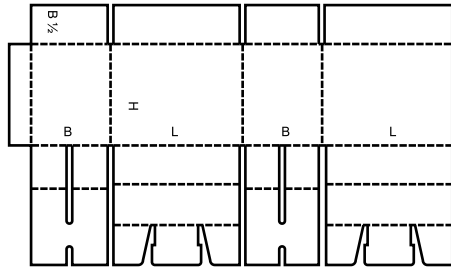

**0208 M**

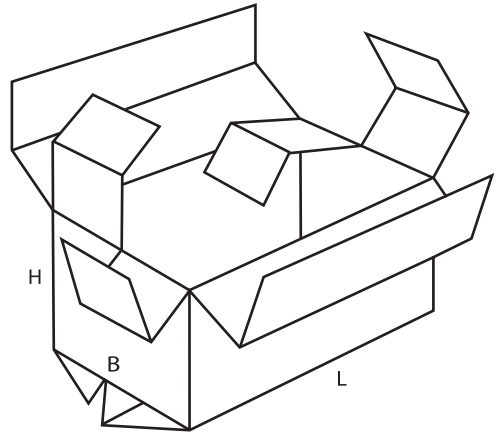
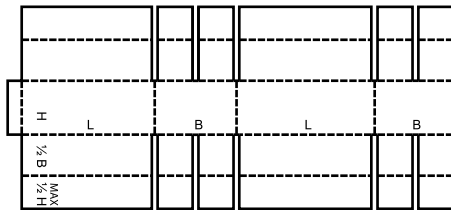

**0209 M/A**

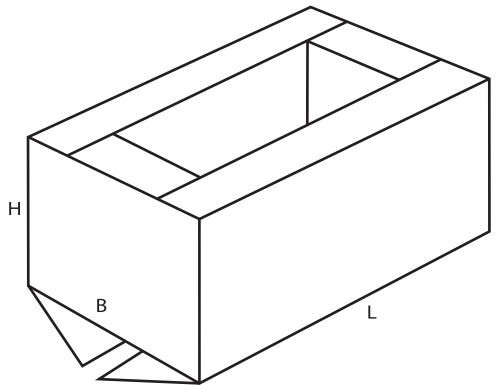
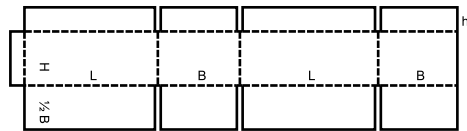

**0210 M**

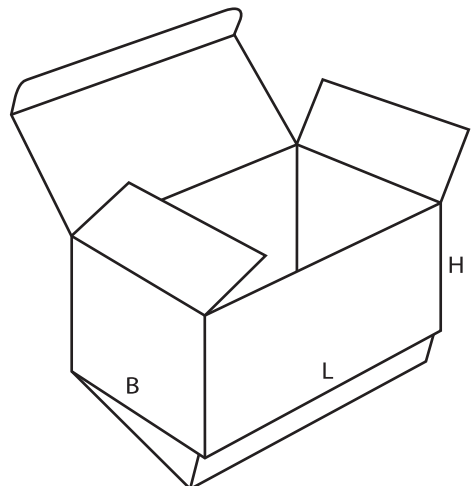
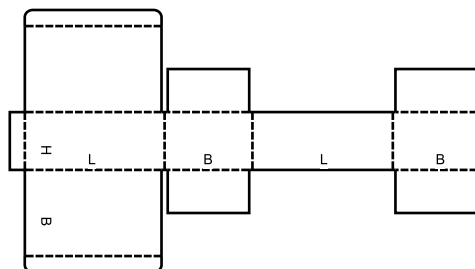

**0211 M**

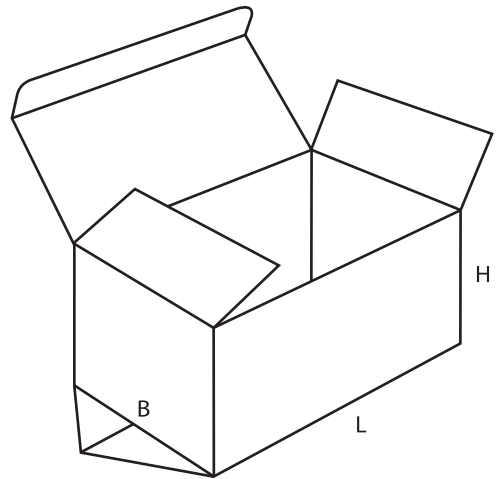
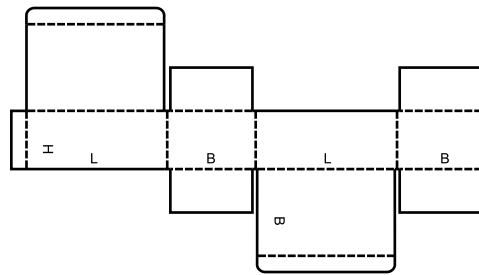

**0212 M/A**

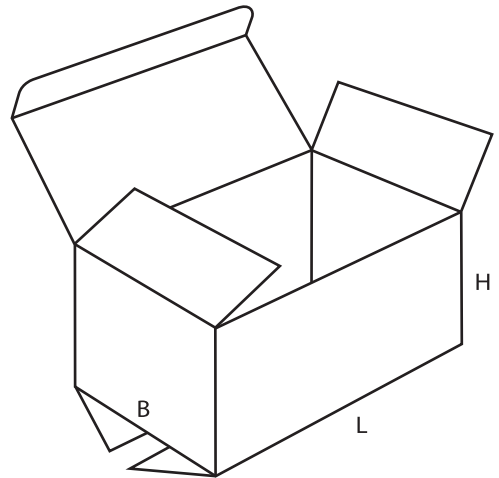
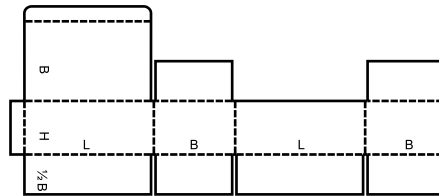

**0214 M**

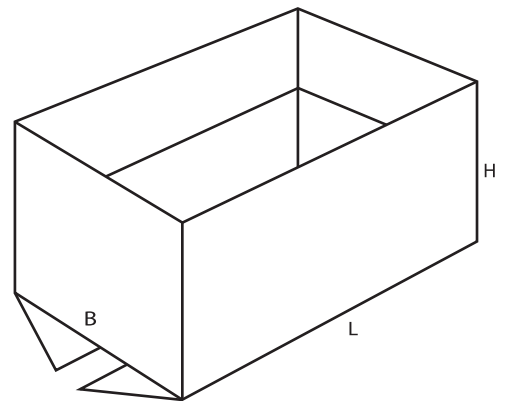
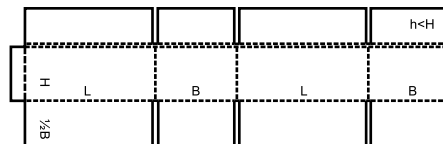

**0215 M**

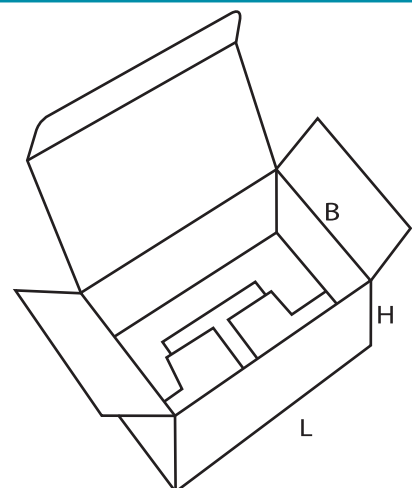
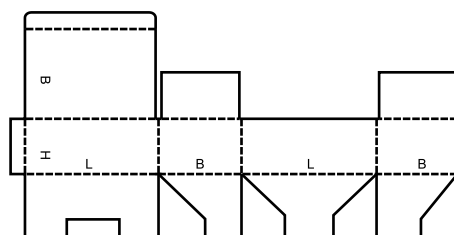

**0216 M**

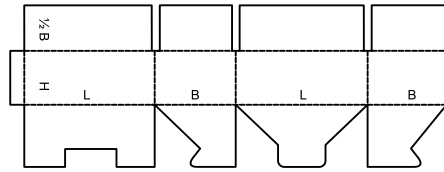

closure of top can be automated  
 la fermeture du dessus peut être automatisée  
 Der Verschluss des Aufsatzes kann automatisiert werden

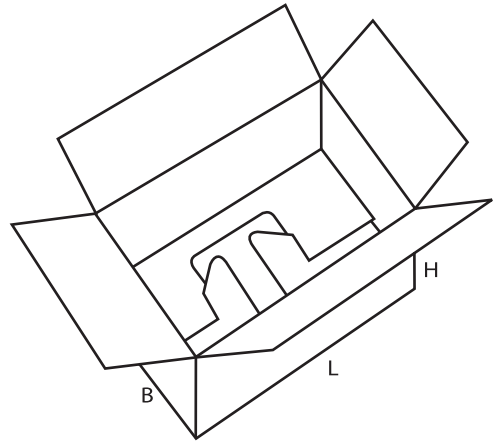

**0217 M**

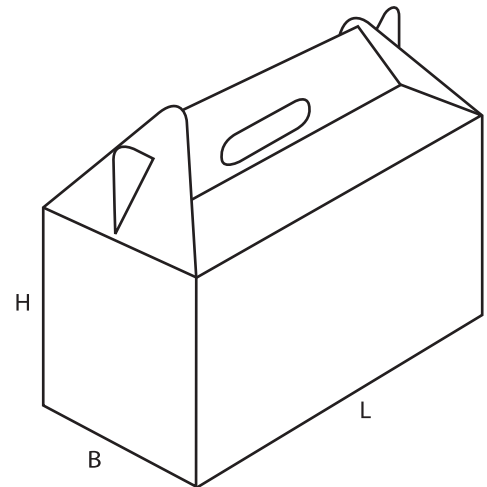
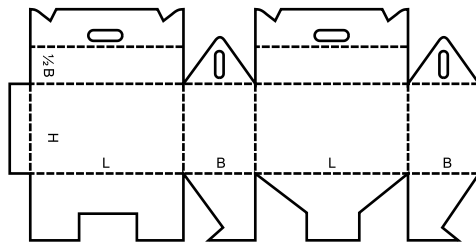

**0218 M**

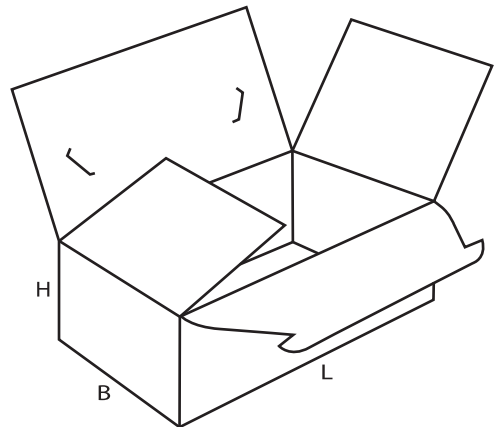
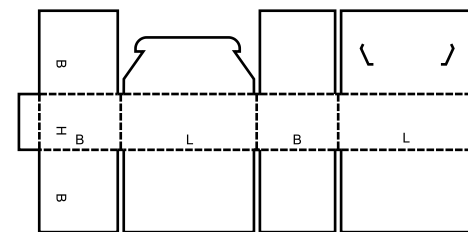

**0225 M**

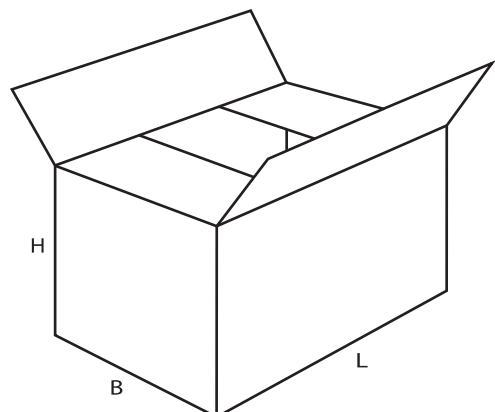
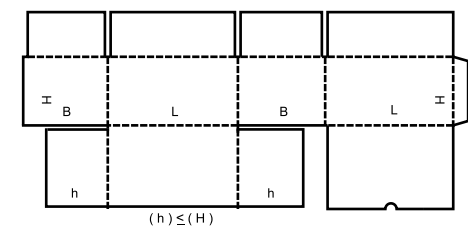

**0226** M

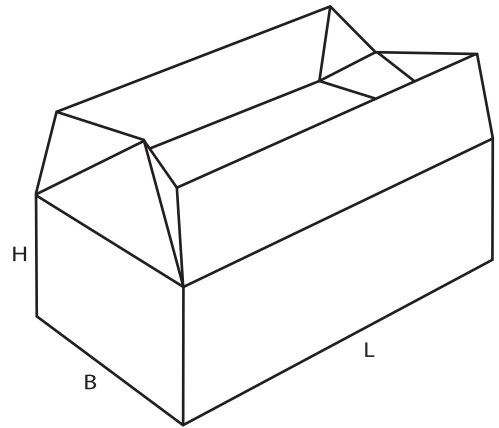
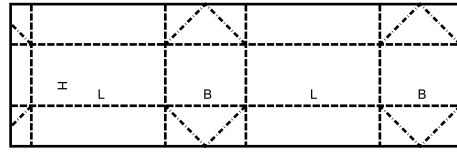

**0227** M

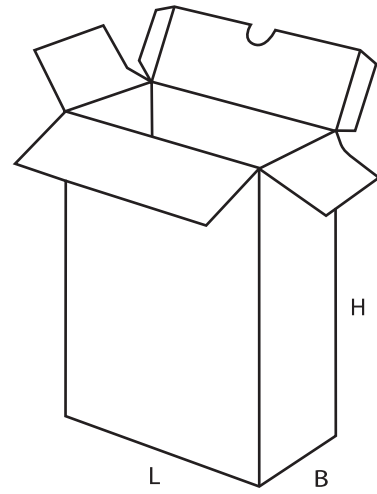
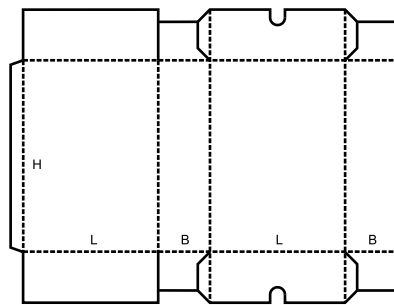

**0228** M/A

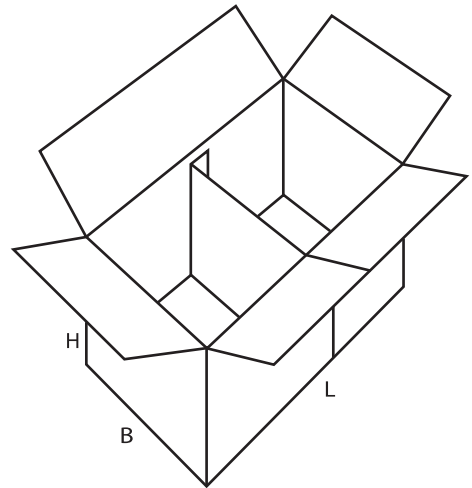
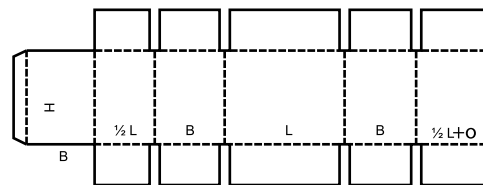

**0229** M

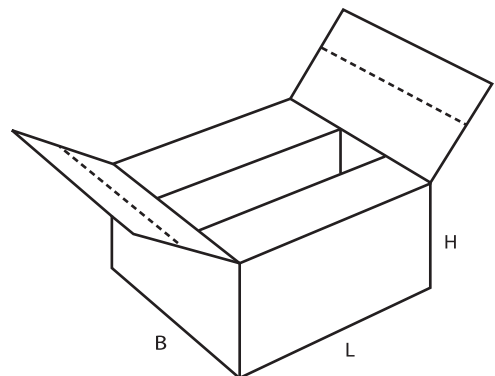
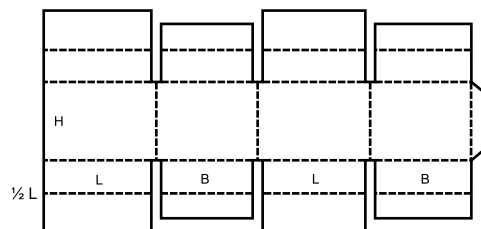

**0230 M/A**

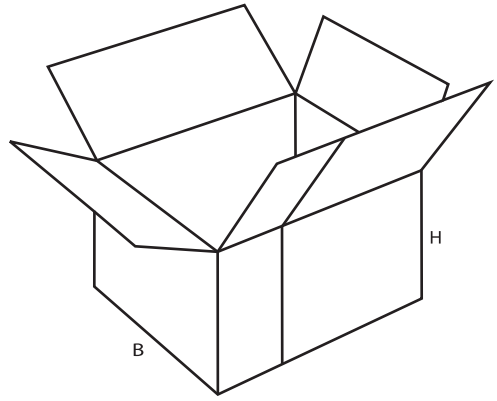
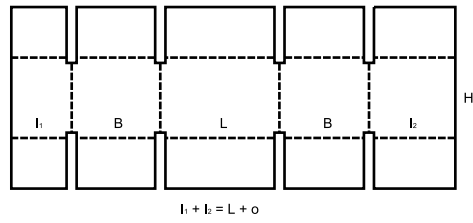

**0231 M/A**

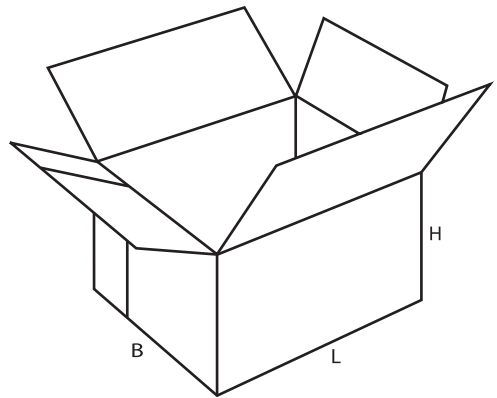
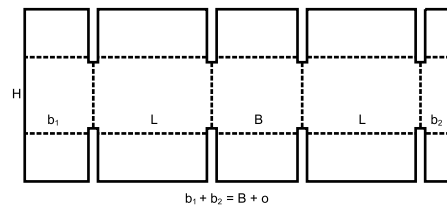

# 0300

- ▲ **Telescope-type** boxes consist of more than one piece and are characterised by a lid and/or bottom telescoping over the body of the box.
- ▲ **Caisses télescopiques** constituées par plus d'une pièce et caractérisées par un couvercle et/ou un fond séparé se glissant sur le corps de la caisse.
- ▲ **Deckelschachteln (Stülp-schachteln)** bestehen aus zwei oder mehr Teilen. Ein Oberteil (Deckel) wird über ein Unterteil (Boden) gestülpt oder beide über einen Rumpf.

- ▲ **Casse telescopiche:** Scatole telescopiche costituite da più di un componente e caratterizzate da un coperchio e/o fondo che scorre esternamente al corpo della scatola.
- ▲ **Cajas telescópicas:** fabricada con más de una pieza, se caracterizan por una tapa y/o fondo que se desliza sobre el cuerpo de la caja.

## 0300 M/A

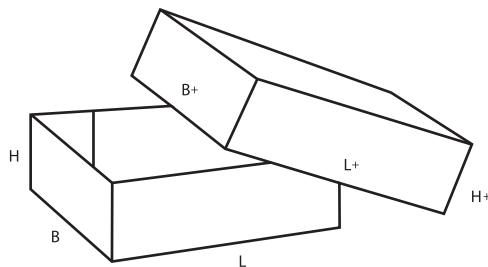
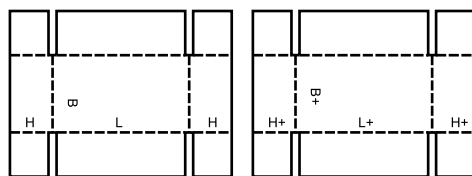

## 0301 M/A

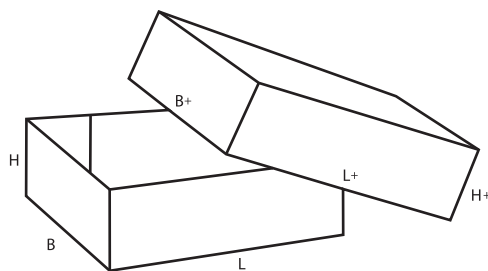
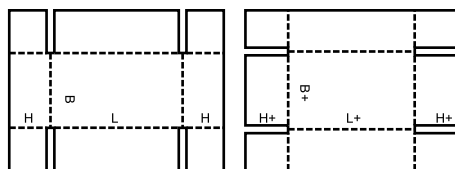

## 0302 M

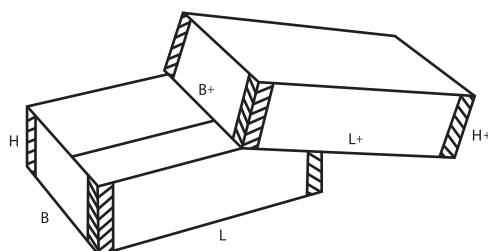
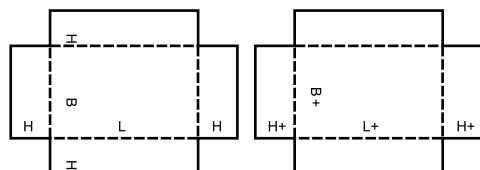

**0303 M**

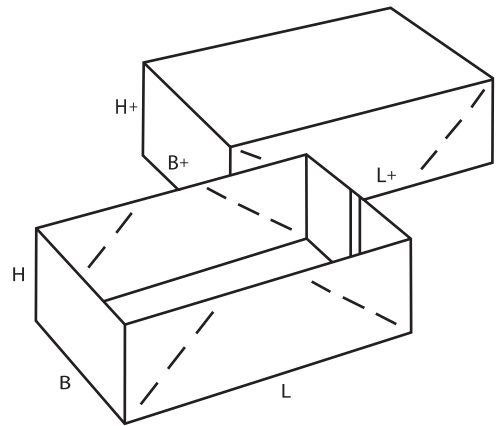
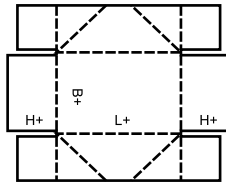
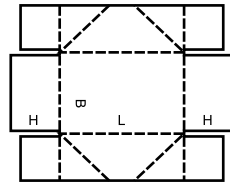

**0304 M**

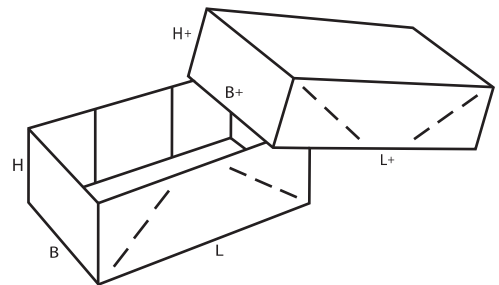
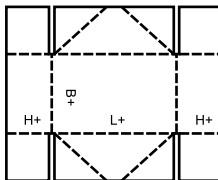
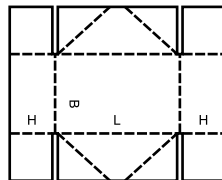

**0306 M/A**

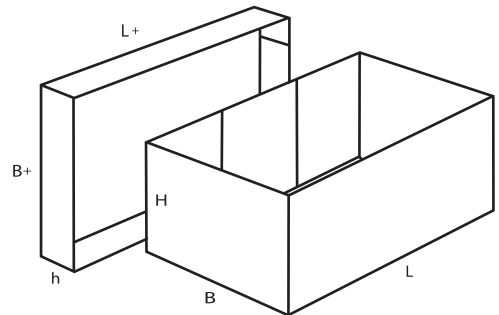
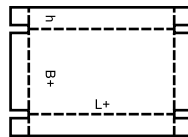
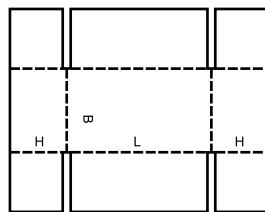

**0307 M**

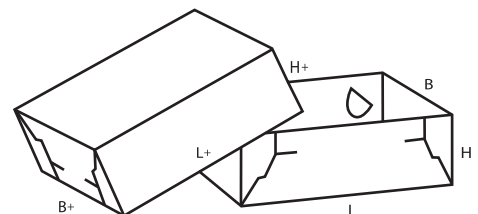
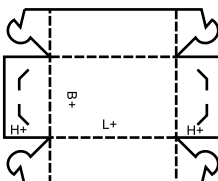
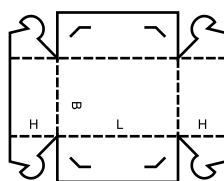

**0308 M**

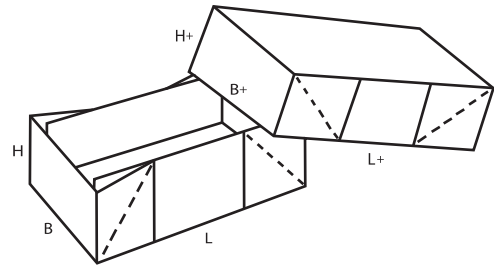
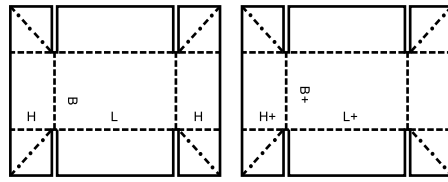

**0309 M**

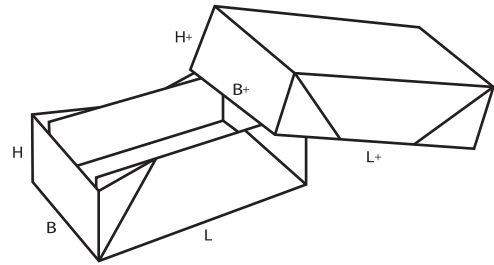
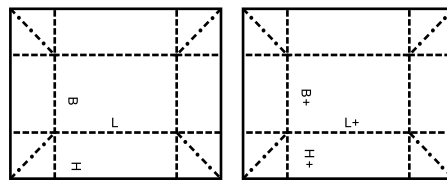

**0310 M+A**

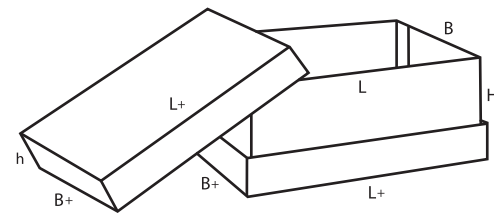
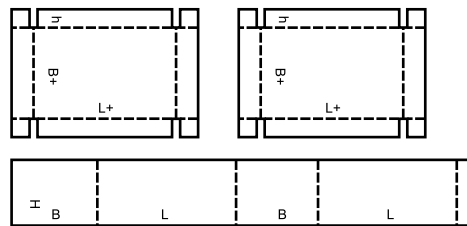

**0312 M/A**

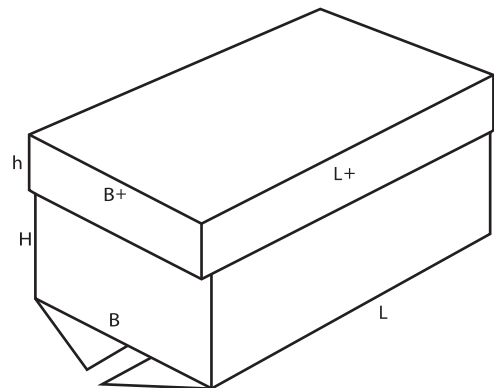
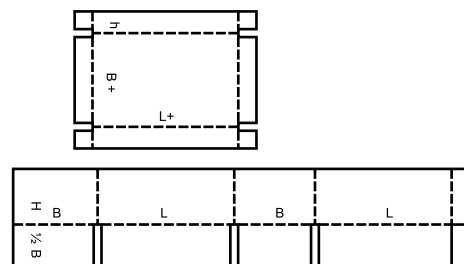

**0313 M/A**

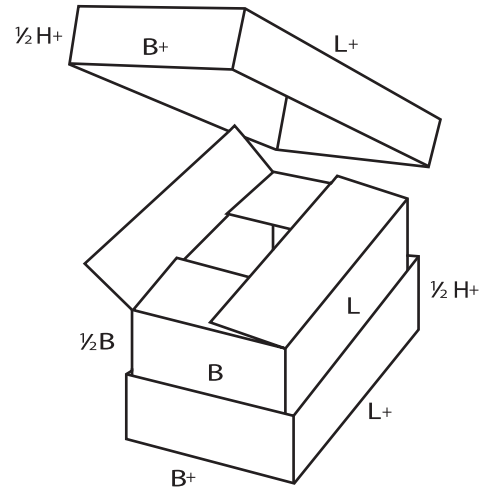
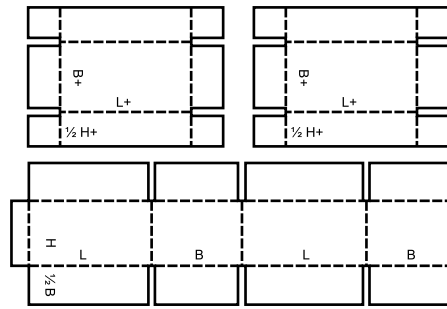

**0314 M**

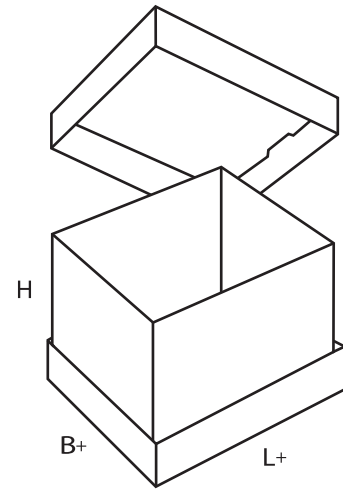
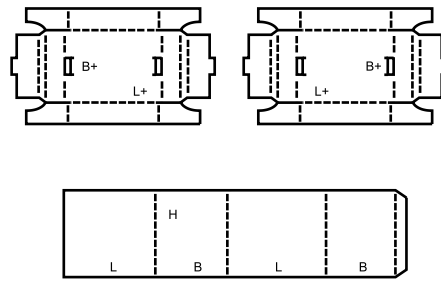

**0320 M/A**

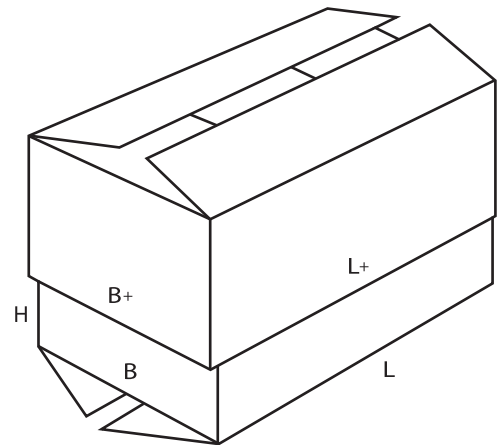
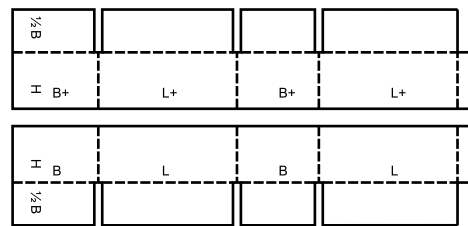

**0321 M**

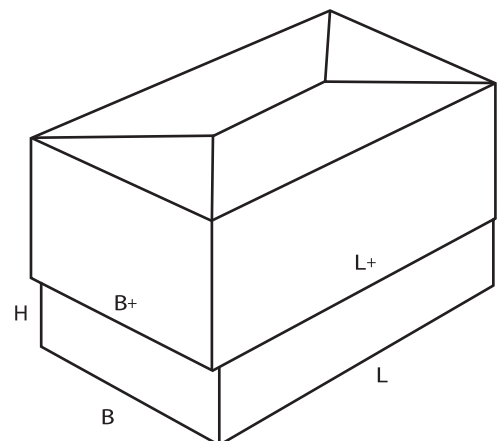
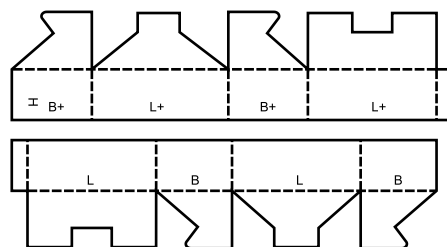

**0322 M**

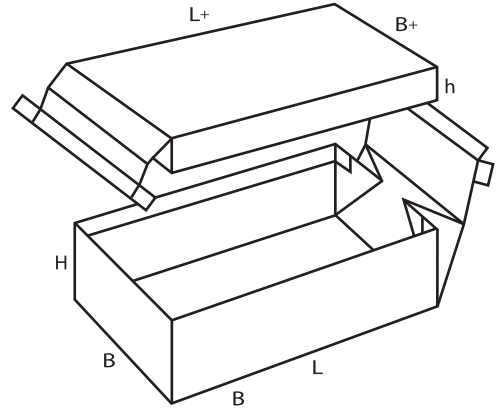
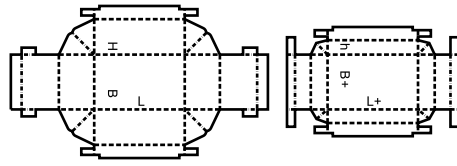

**0323 M**

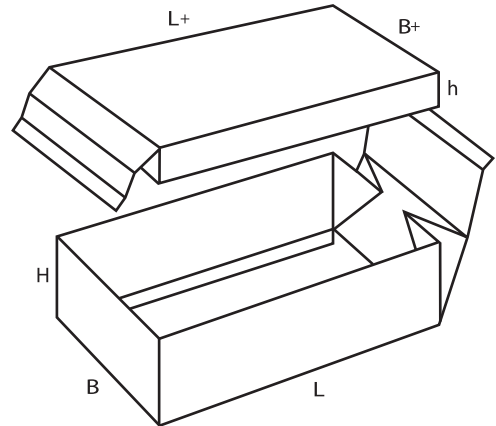
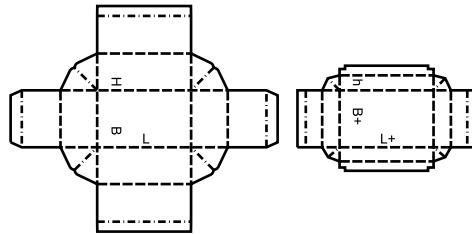

**0325 A**

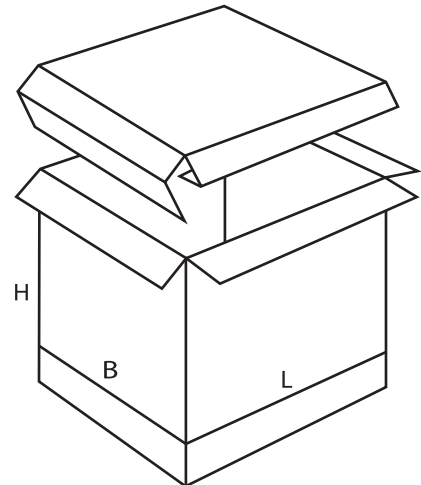
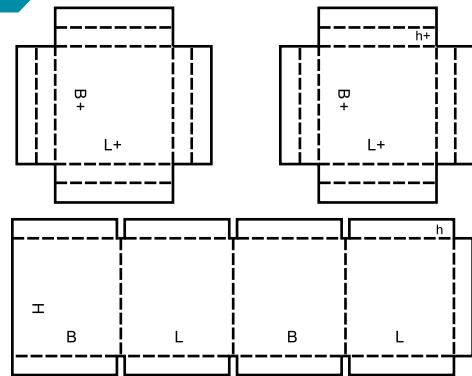

**0330 M/A**

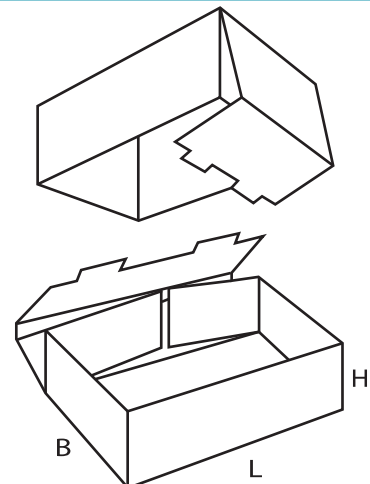
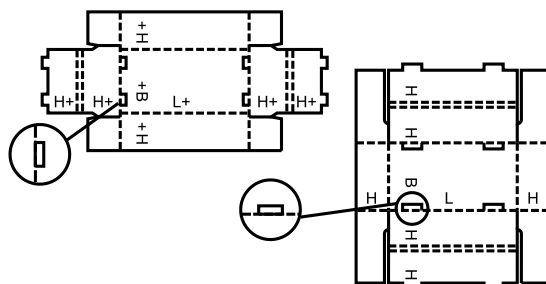

**0331 M/A**

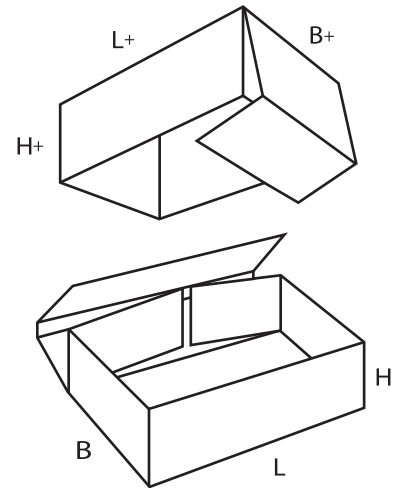
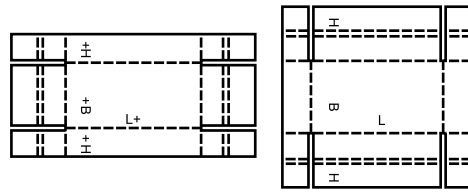

**0350 M**

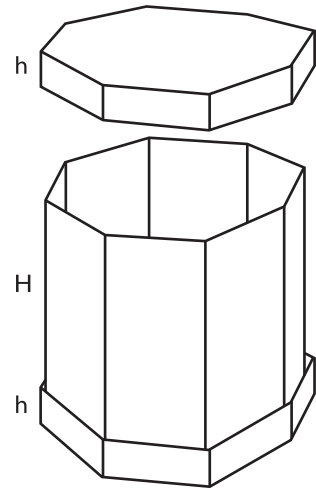
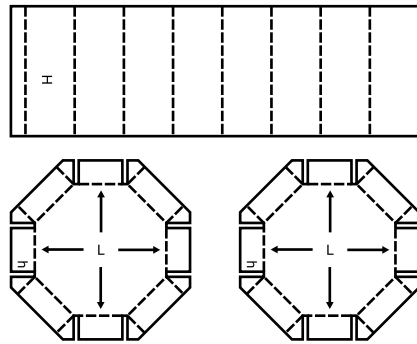

**0351 M/A**

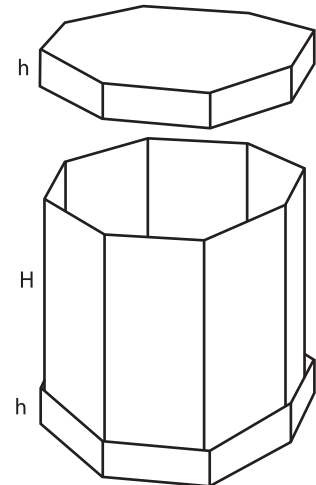
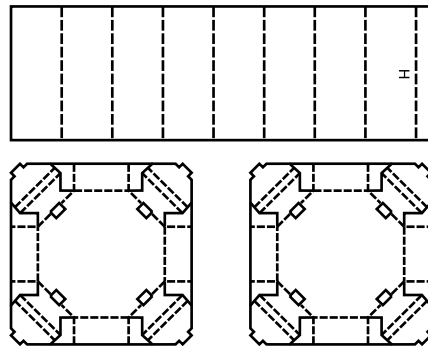

**0352 M/A**

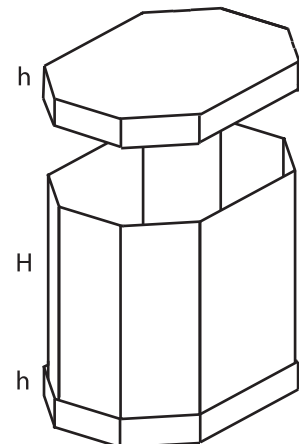
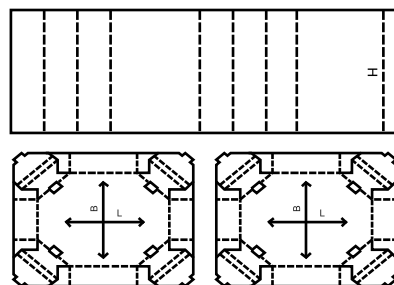

# 0400

- Folder-type boxes** and trays usually consist of only one piece of board. The bottom of the box is hinged to form two or all side walls and the cover. Locking tabs, handles, display panels etc., can be incorporated in some designs.
- Enveloppes et plateaux** en général constitués d'une seule pièce, montés sans agrafage ni bande gommée, et pouvant comporter des éléments de verrouillage, d'encliquetage, et des poignées.
- Falzhüllen und Trays** bestehen im allgemeinen aus einem Zuschnitt. Zwei oder alle Seitenwände und der Deckel sind am Boden angelenkt. Sperrvorrichtungen, Handgriffe, Verkaufsteller usw. können bei dieser

Ausführungsart mit vorgesehen werden.

- Scatole pieghevoli e vassoi:** Contenitori e vassoi formati normalmente dalla piegatura di un pezzo di cartone. Il fondo del contenitore è delimitato da pieghe in modo da formare due o tutti i pannelli laterali ed il pannello superiore. In certi modelli possono essere incorporati delle linguette di chiusura, delle maniglie, dei pannelli da espositori ecc.
- Cajas plegables y bandejas:** son en general de una única pieza de cartón ondulado. El fondo de la caja se pliega para formar dos, o todas las paredes laterales, y la tapa. Pueden incorporarse al diseño elementos de cierre, asas, paneles expositores, etc.

## 0400 M

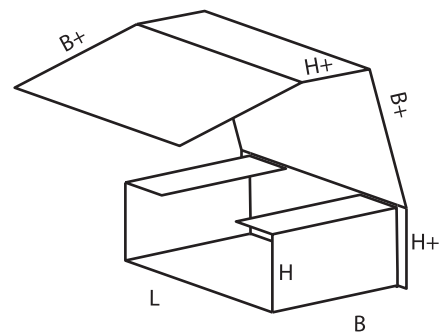
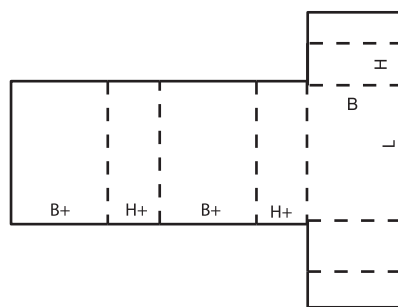

## 0401 M

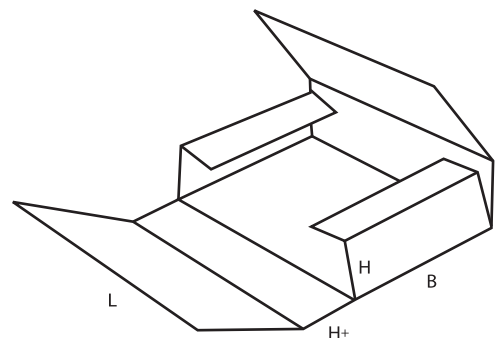
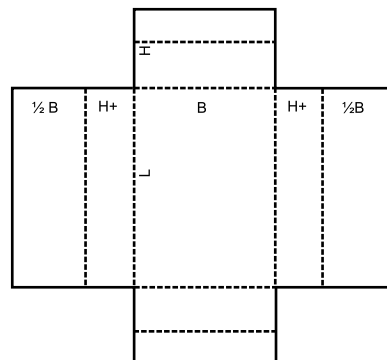

## 0402 M

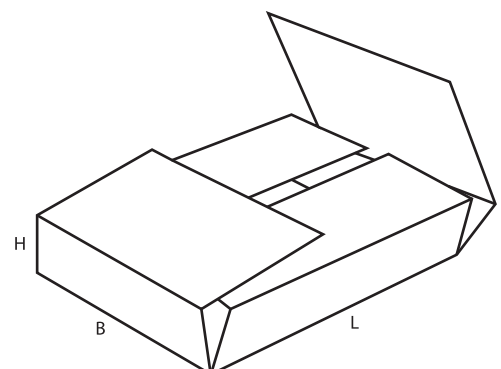
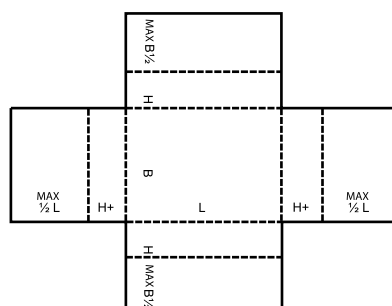

**0403 M**

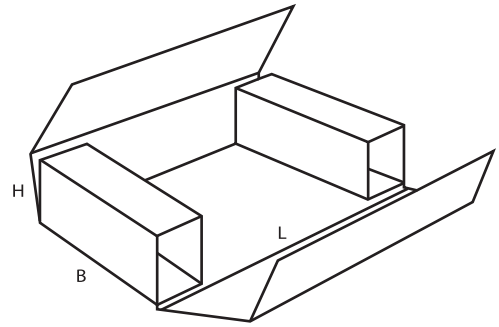
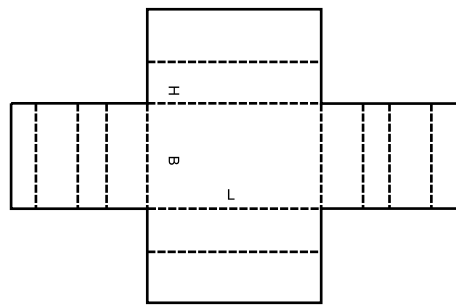

**0404 M**

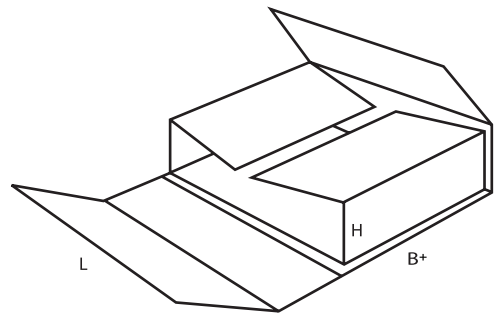
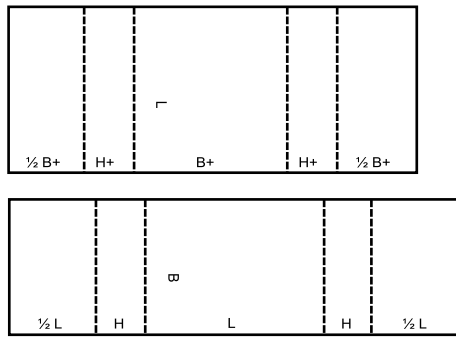

**0405 M**

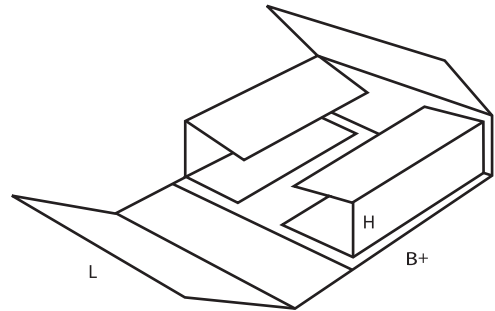
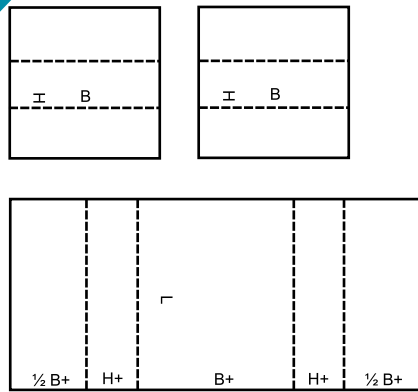

**0406 A**

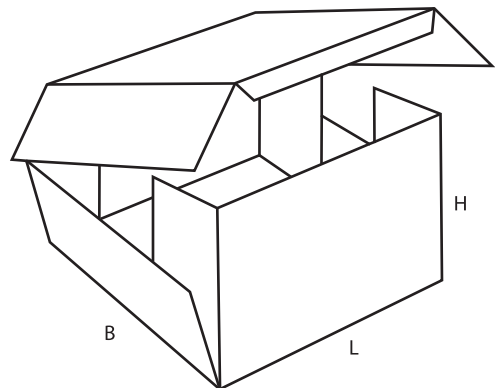
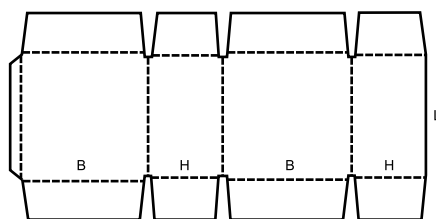

**0409** M

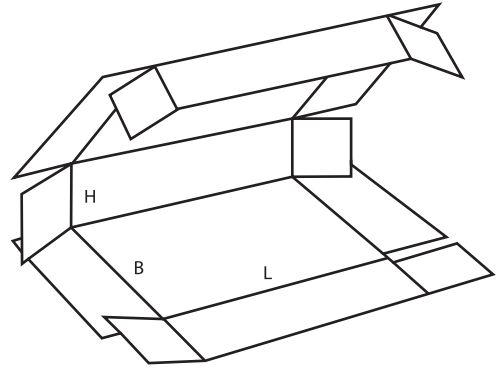
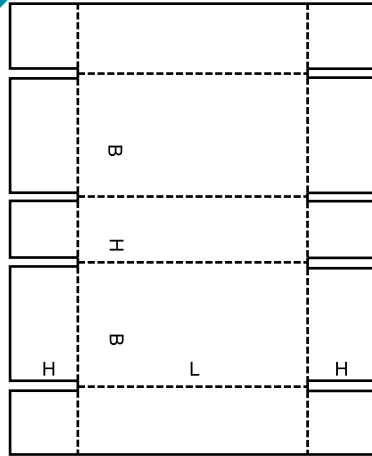

**0410** M/A

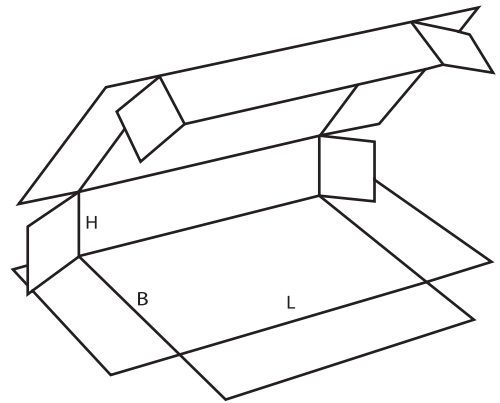
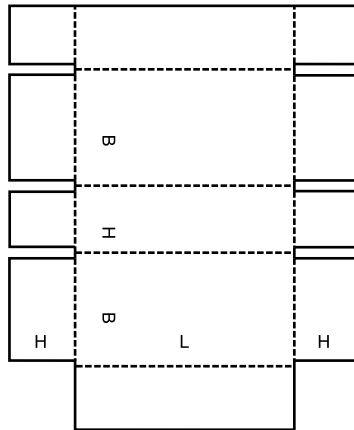

**0411** M/A

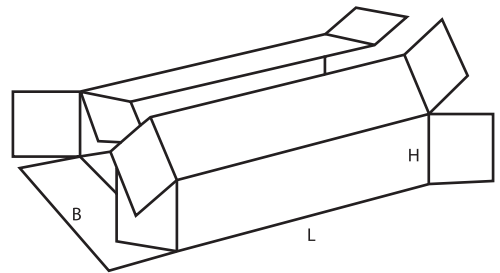
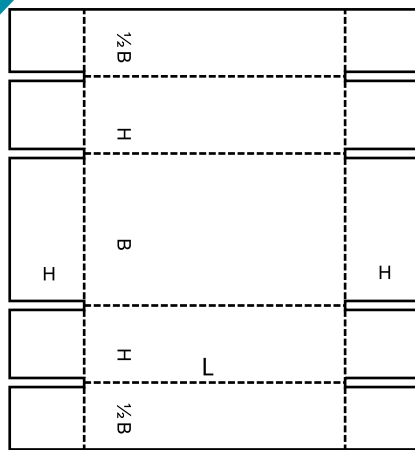

**0412** M

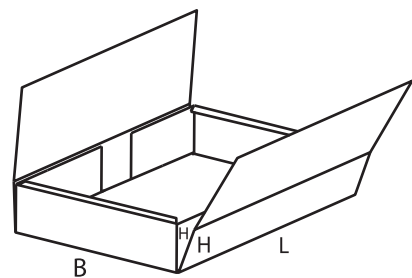
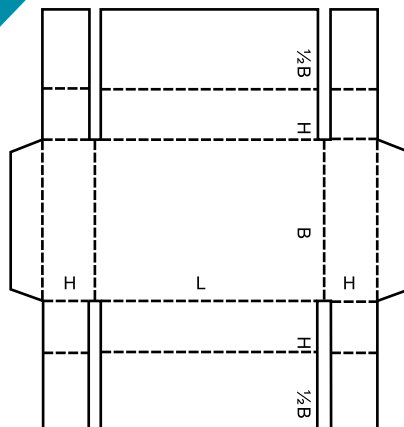

**0413** M/A

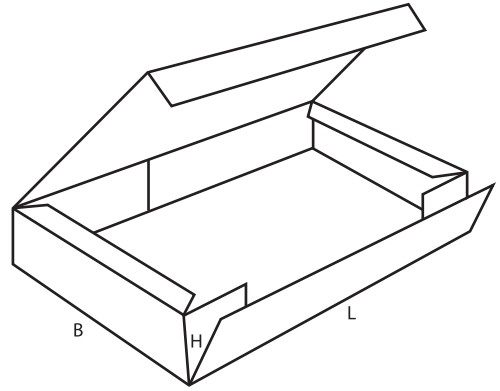
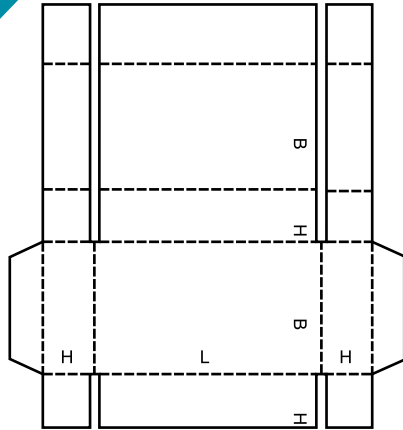

**0415** M/A

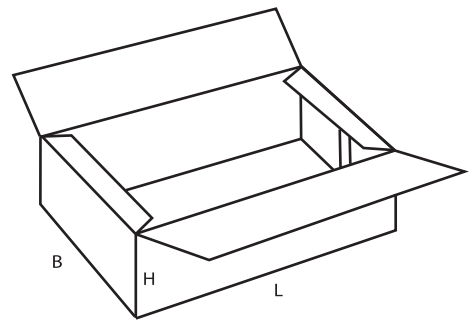
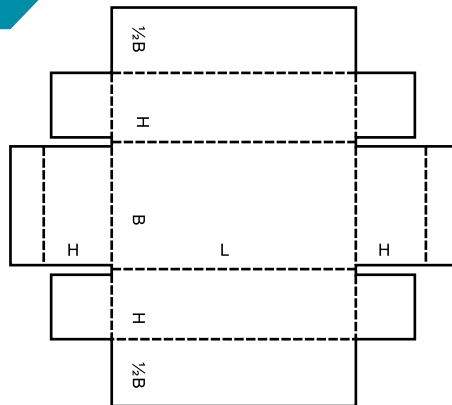

**0416** M

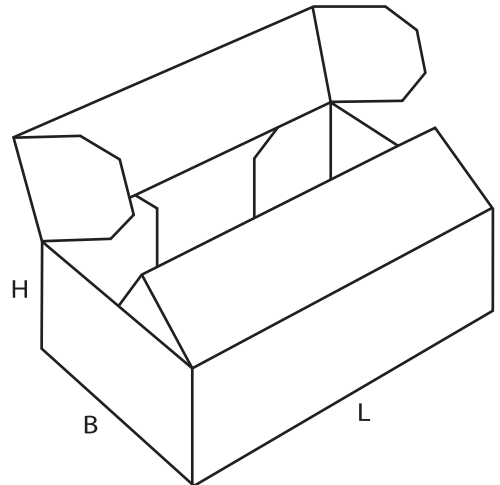
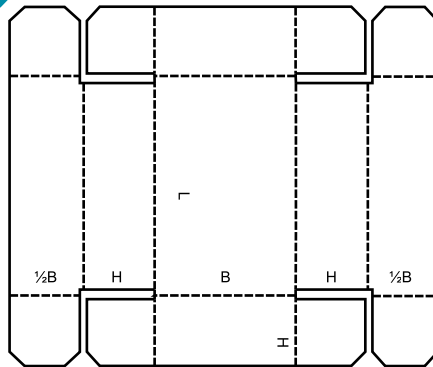

**0420** M/A

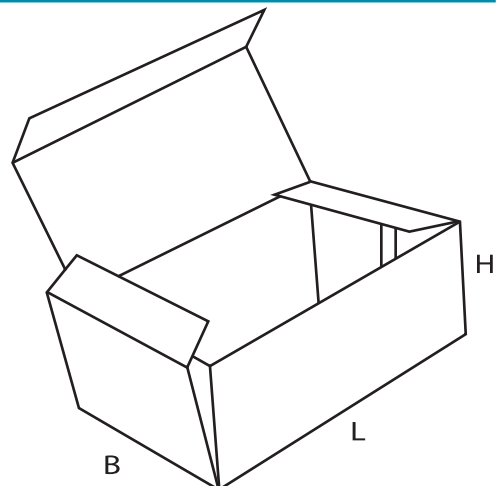
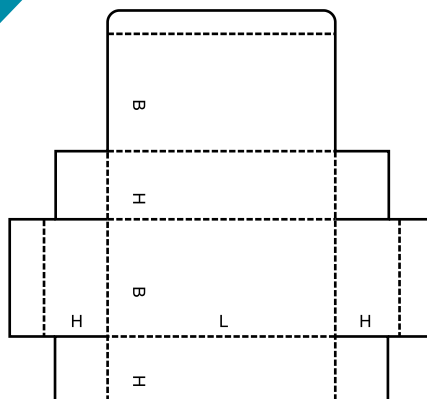

**0421** M/A

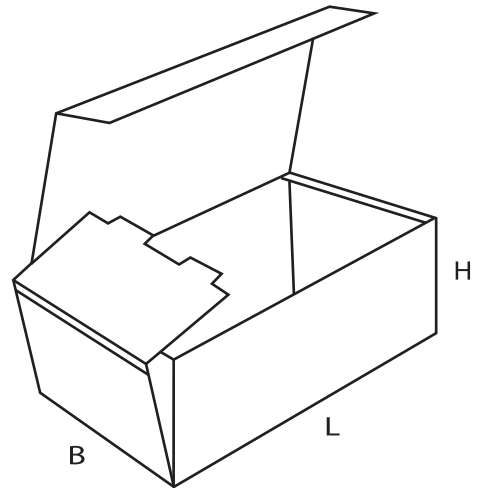
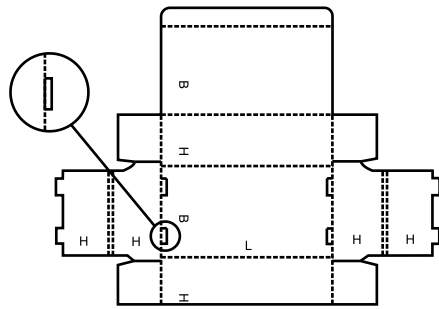

**0422** M/A

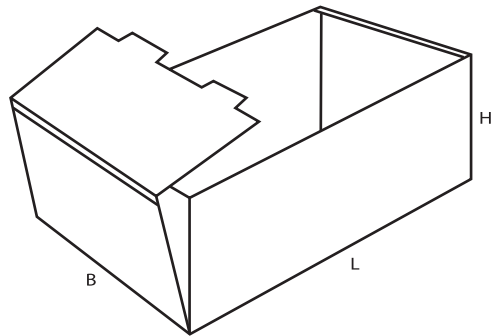
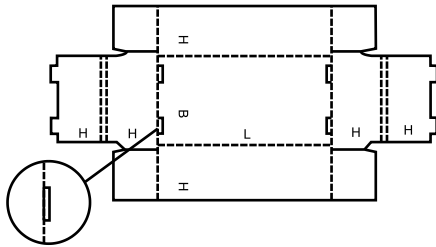

**0423** M/A

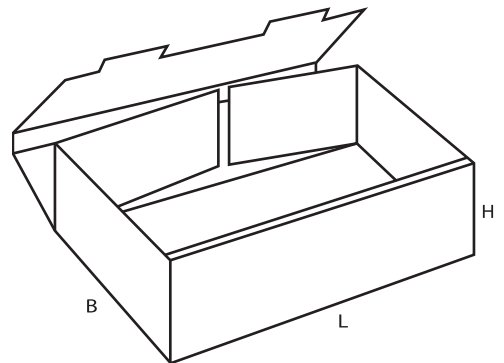
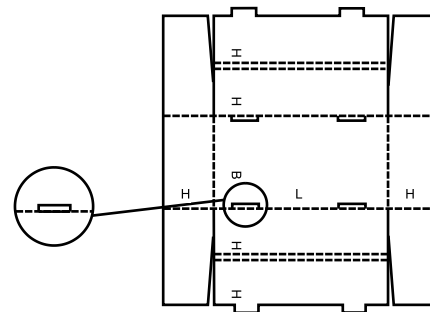

**0424** M/A

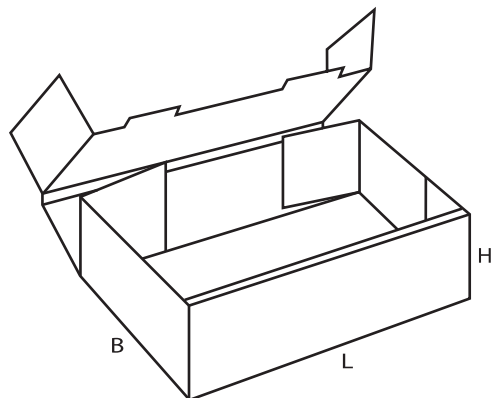
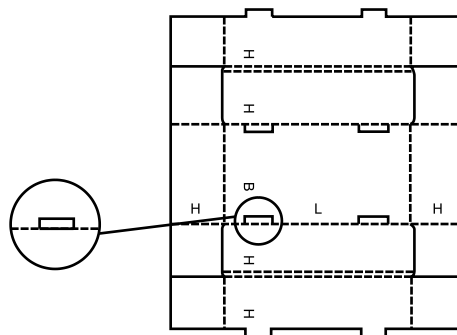

**0425 M/A**

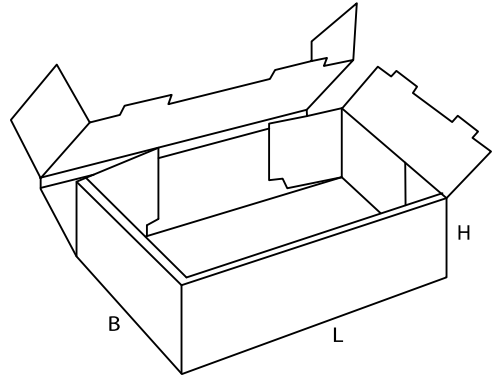
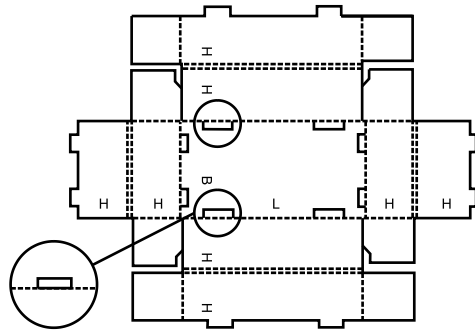

**0426 M**

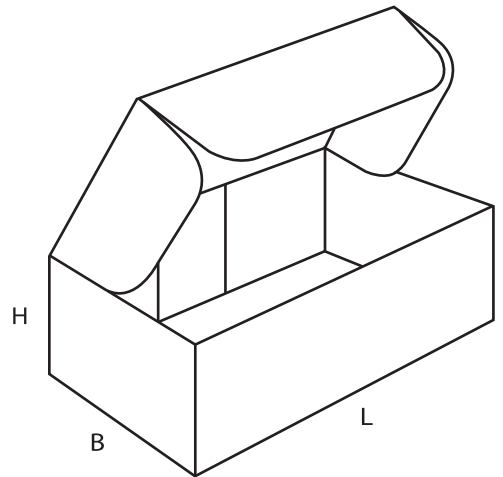
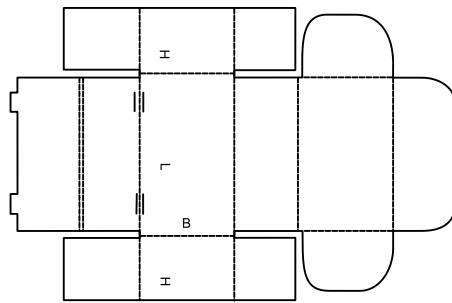

**0427 M**

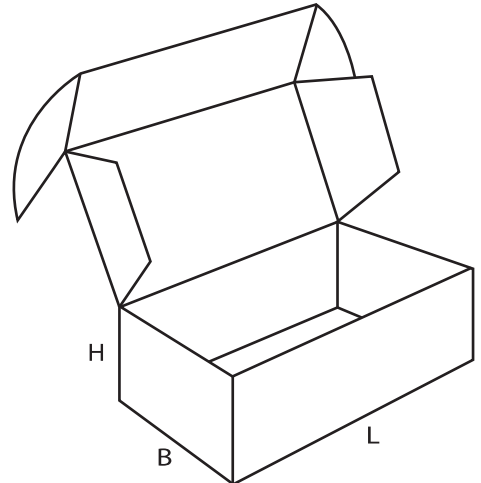
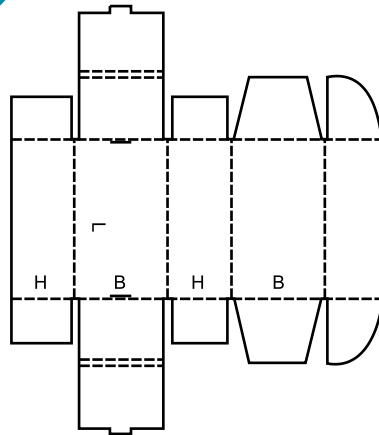

**0428 M**

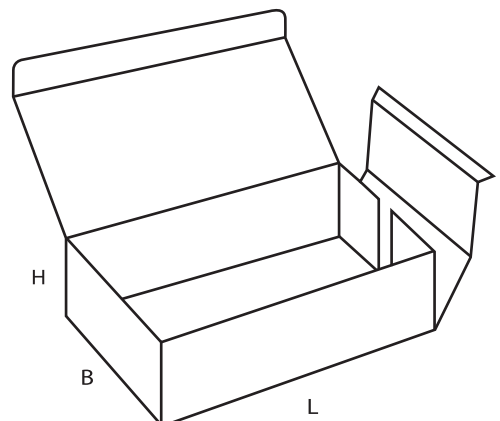
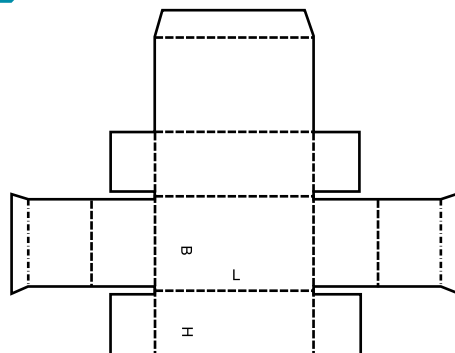

**0429** M

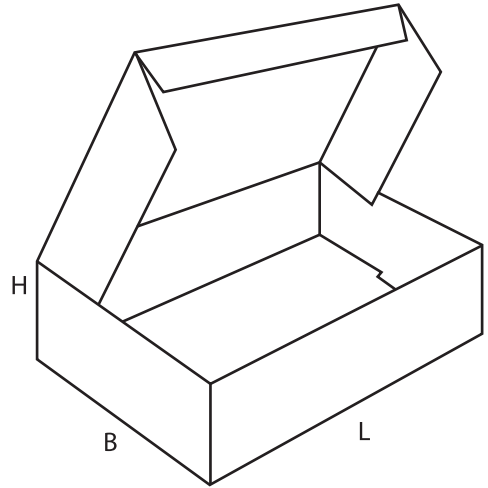
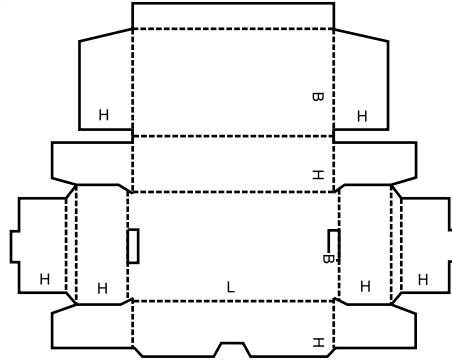

**0430** M/A

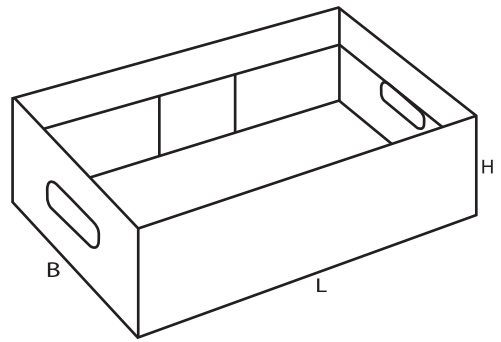
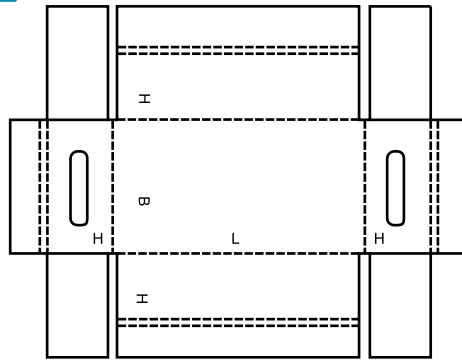

**0431** M

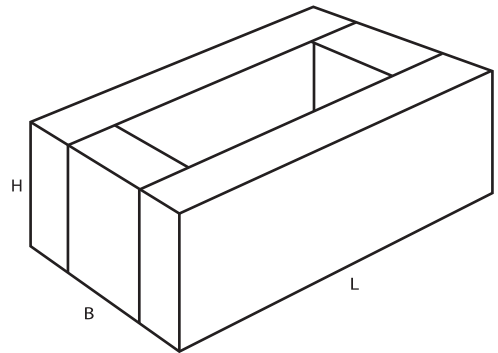
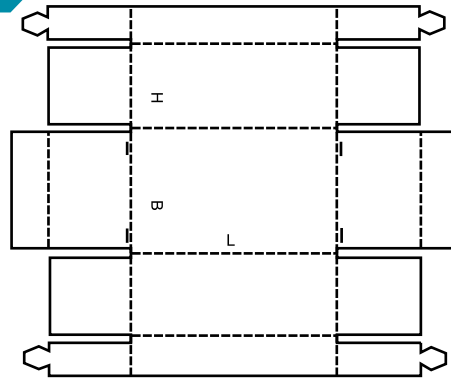

**0432** M

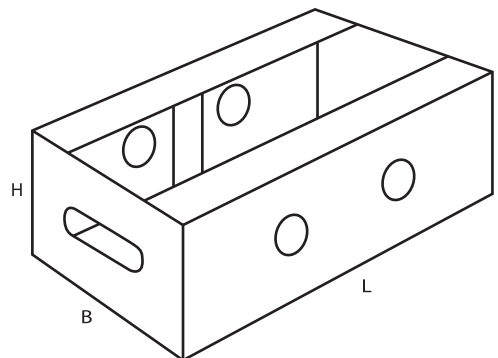
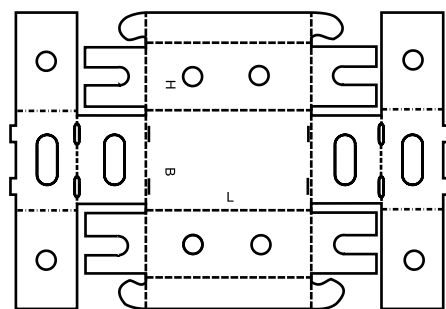

**0433 M**

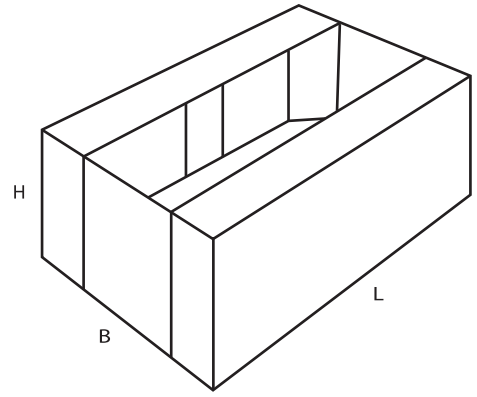
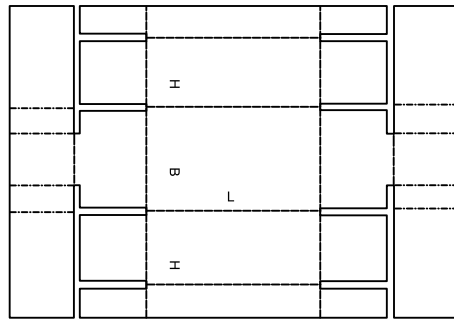

**0434 M**

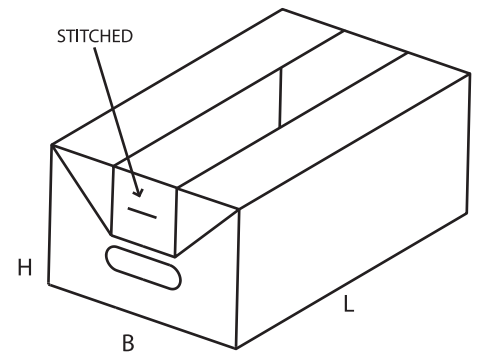
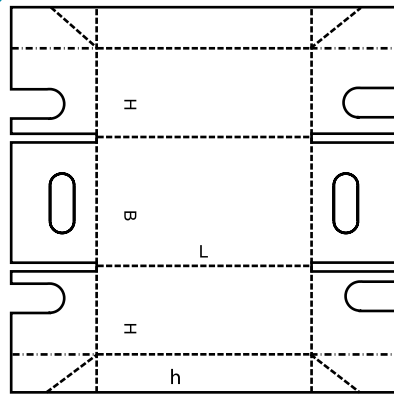

**0435 M/A**

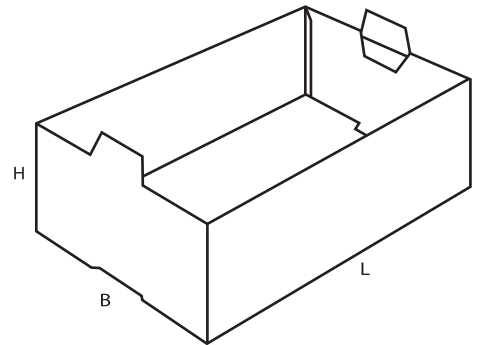
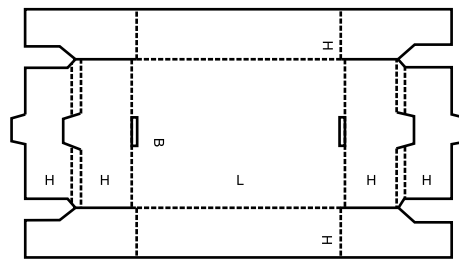

**0436 M**

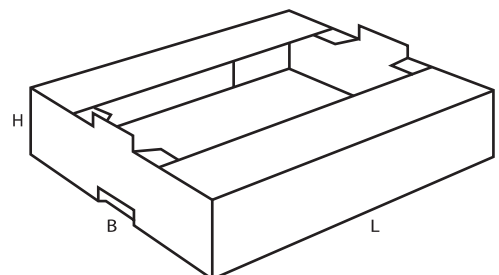
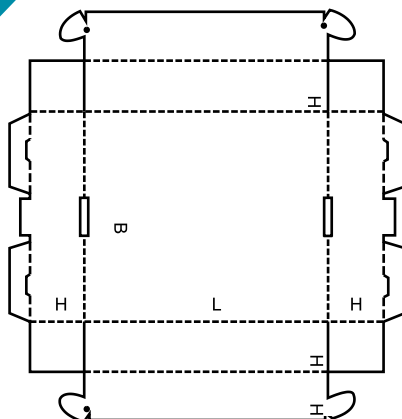

**0437** M

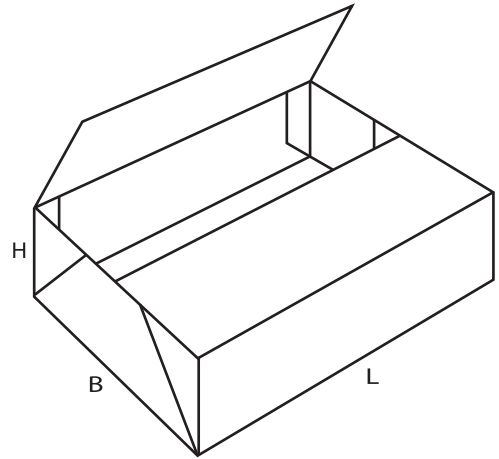
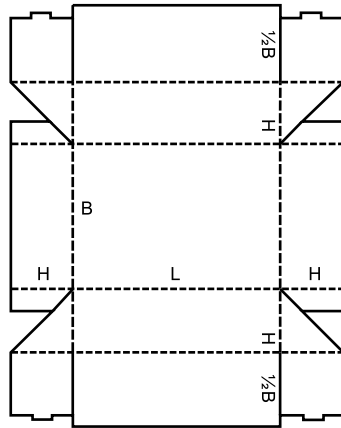

**0440** A

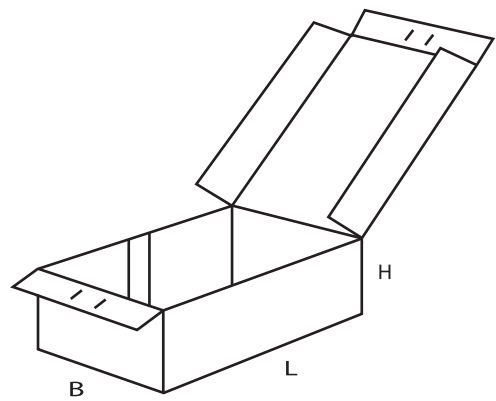
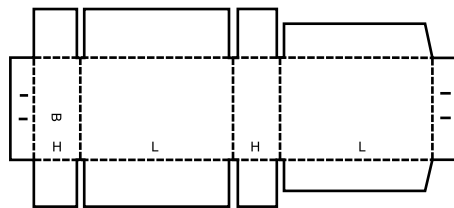

**0441** A

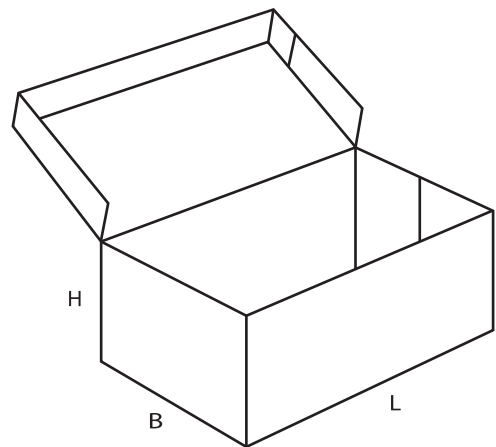
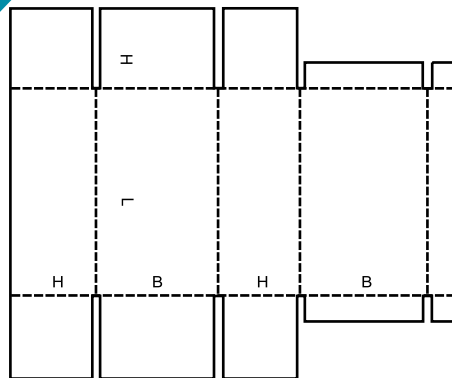

**0442** M

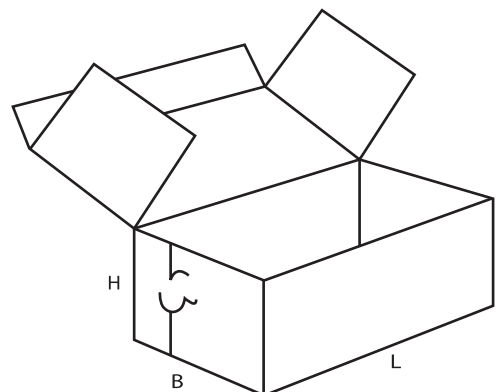
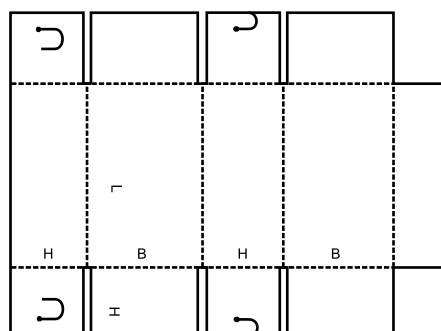

**0443** M

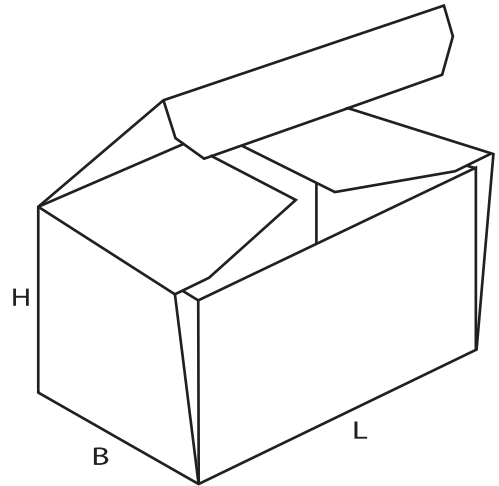
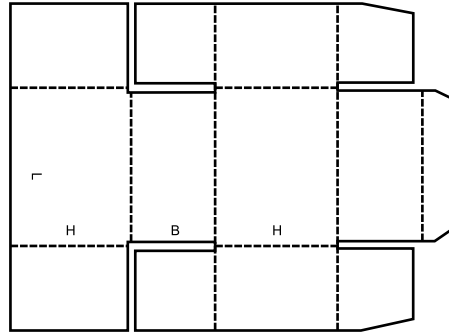

**0444** M

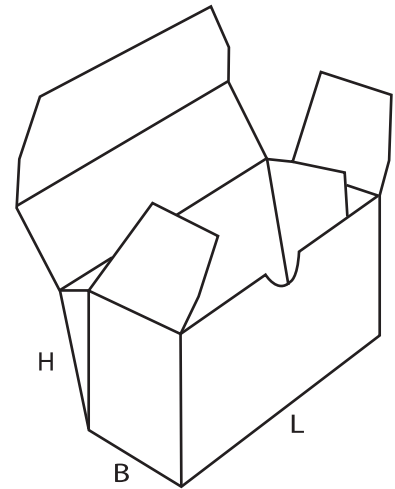
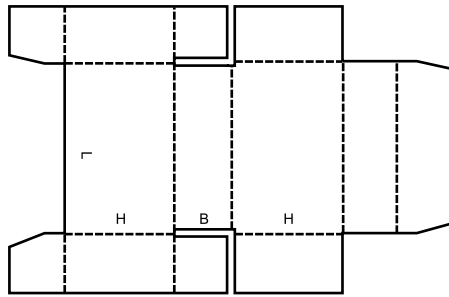

**0445** M

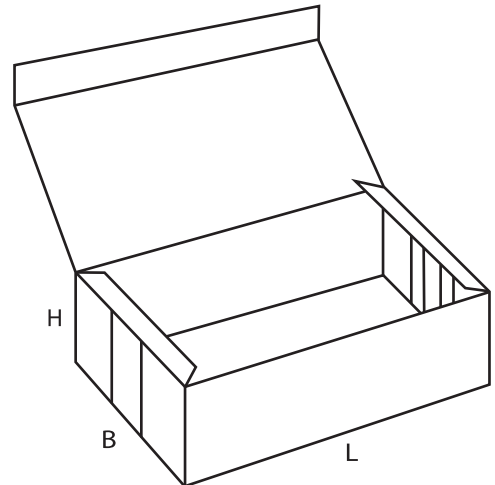
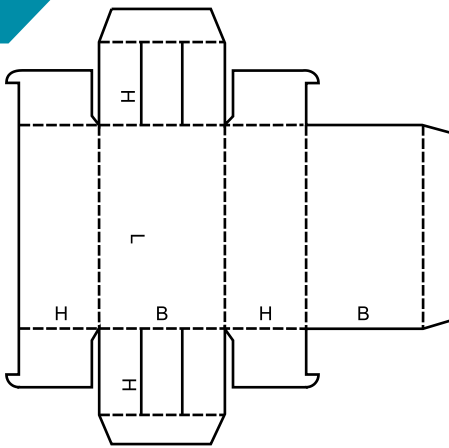

**0446** A

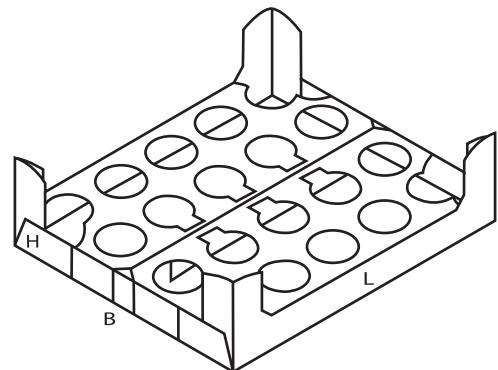
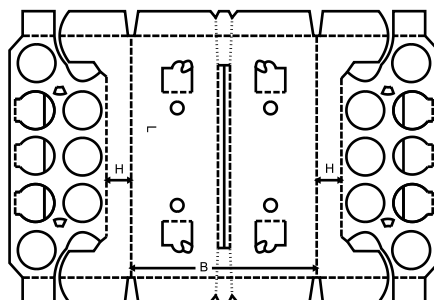

**0447** M

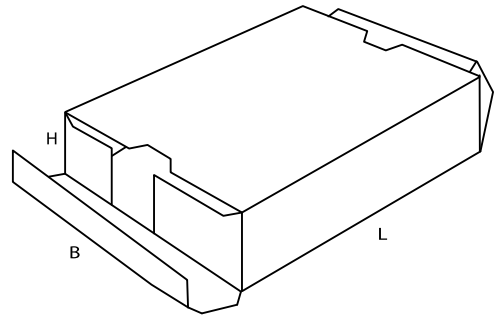
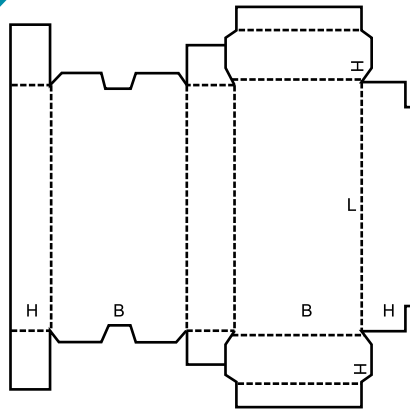

**0448** M

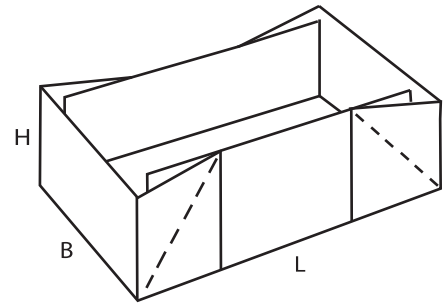
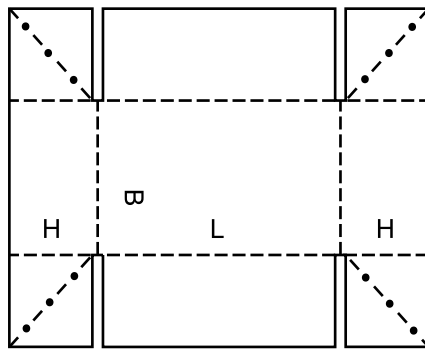

**0449** M

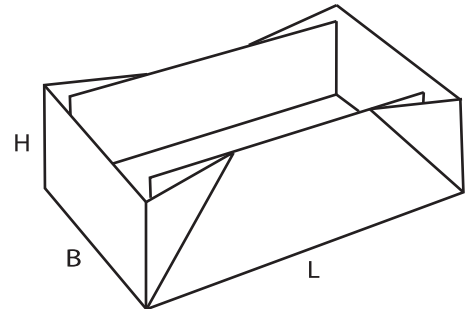
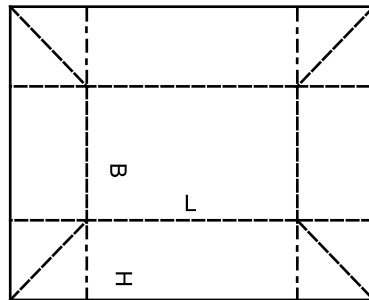

**0450** M

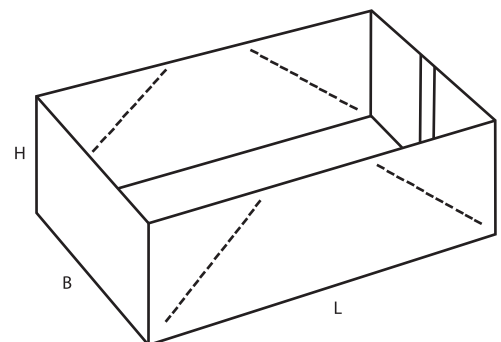
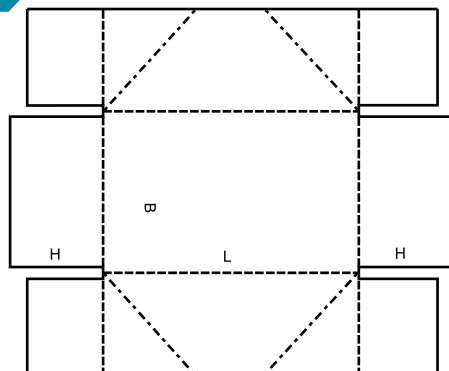

**0451 M**

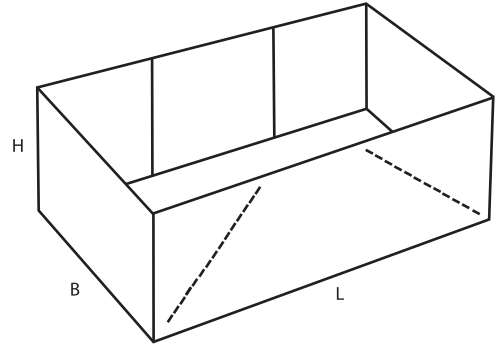
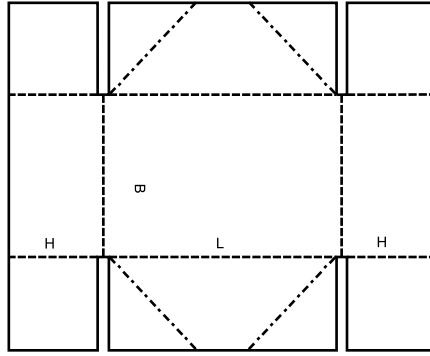

**0452 A**

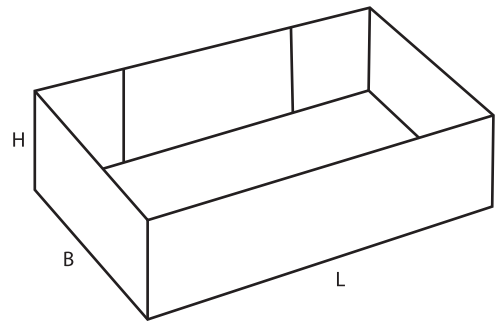
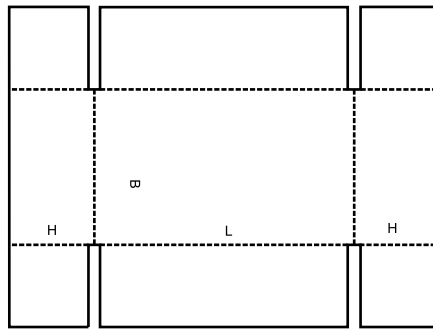

**0453 A**

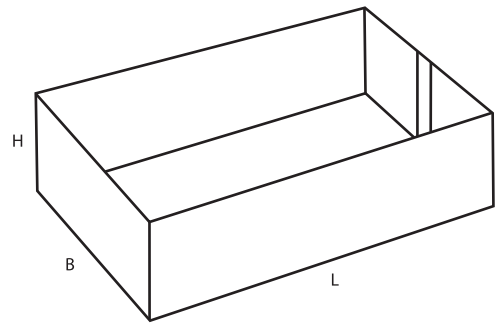
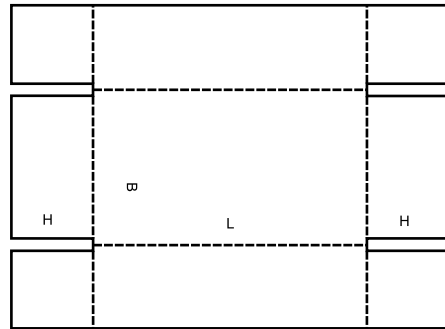

**0454 M**

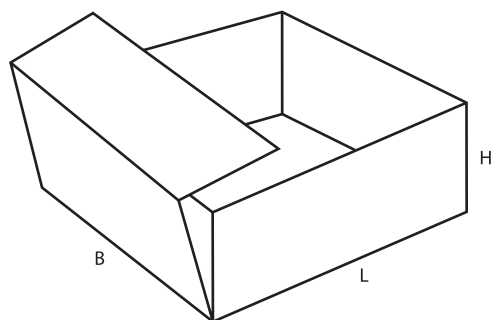
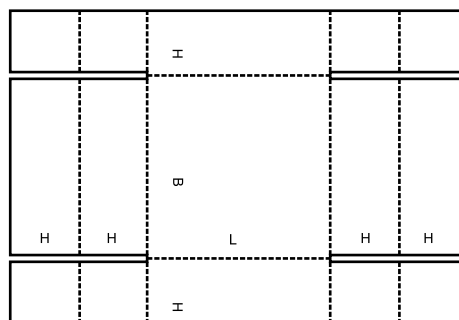

**0455** M

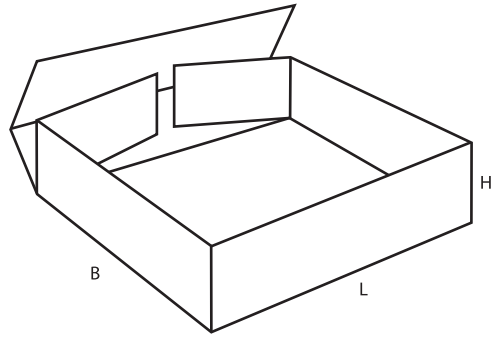
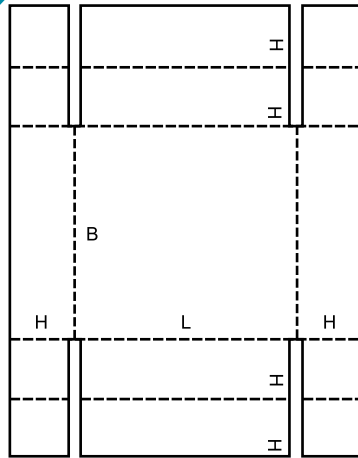

**0456** M

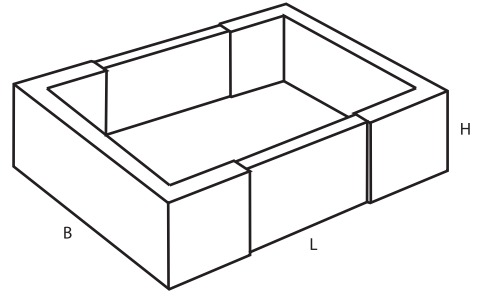
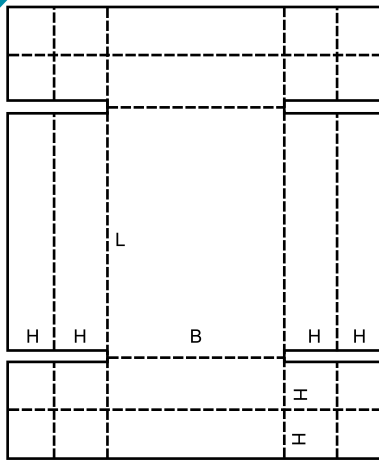

**0457** M

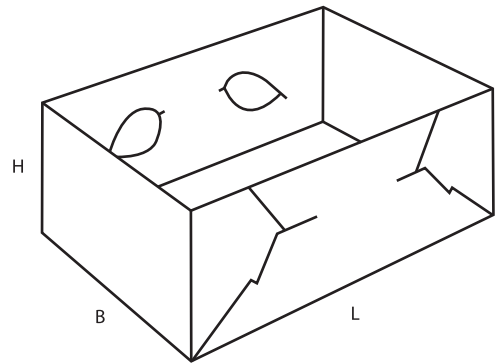
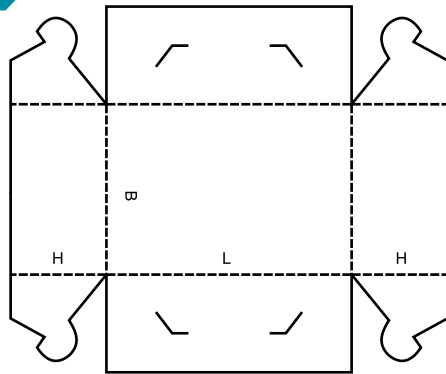

**0458** M

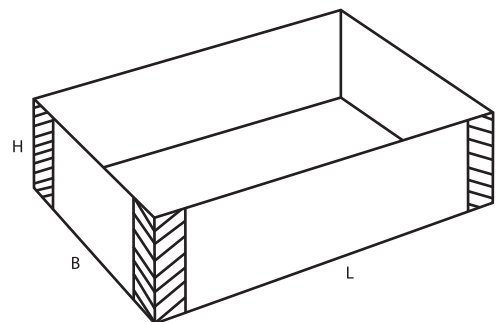
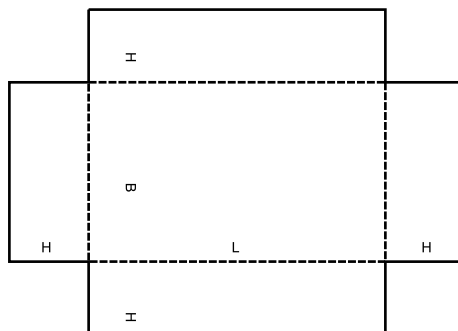

**0459** A

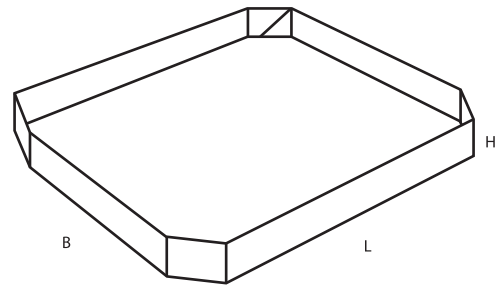
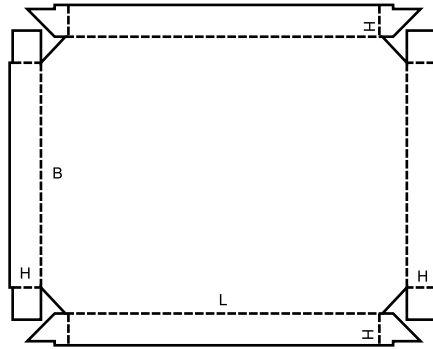

**0460** A

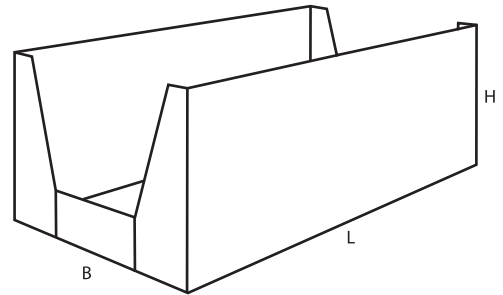
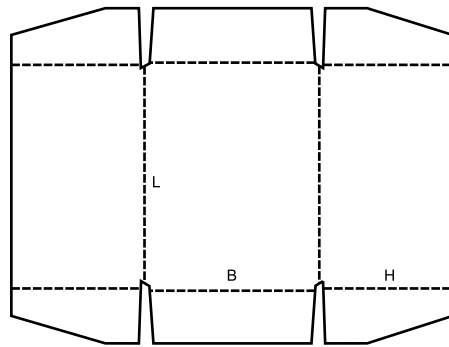

**0470** M

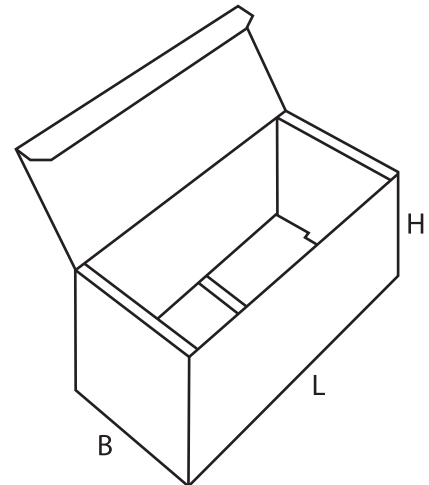
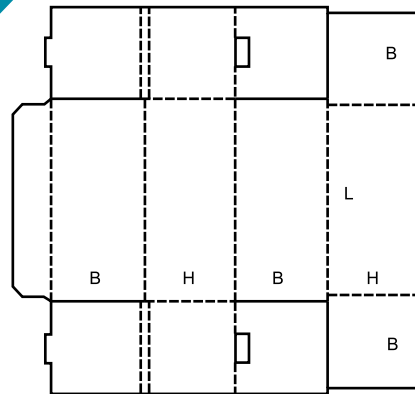

**0471** M

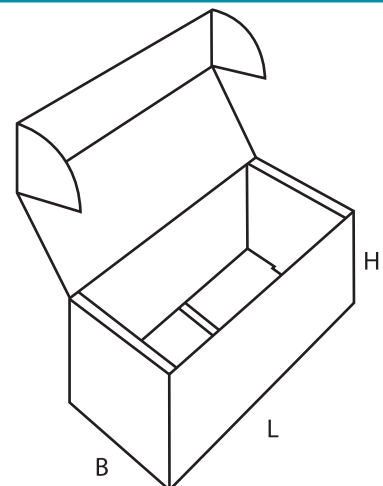
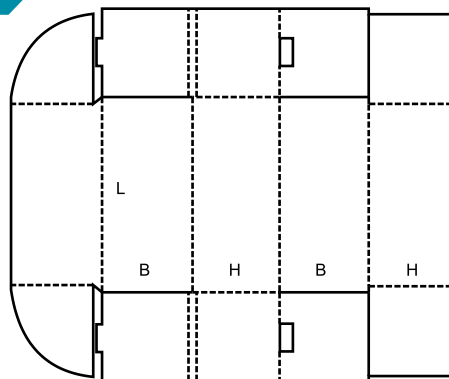

**0472 M**

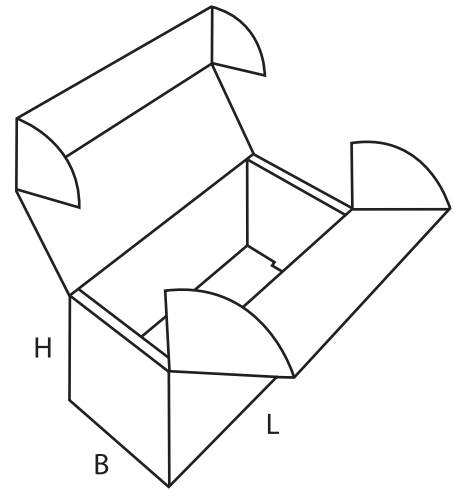
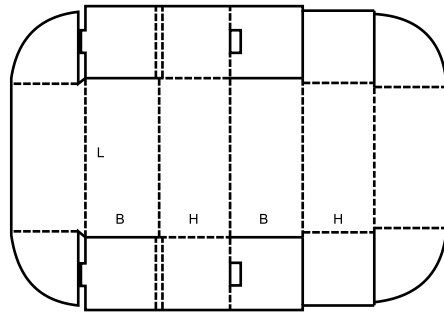

**0473 M**

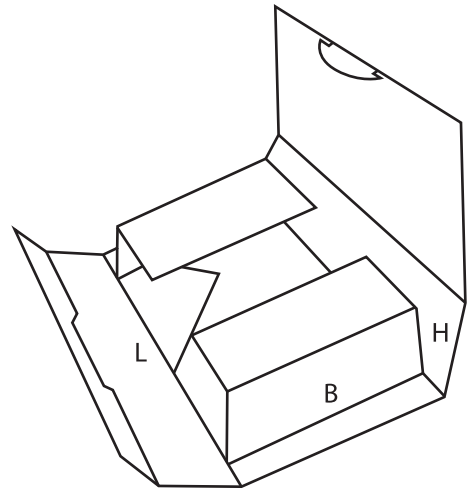
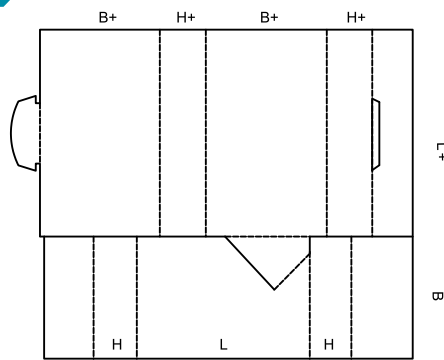

**0480 A**

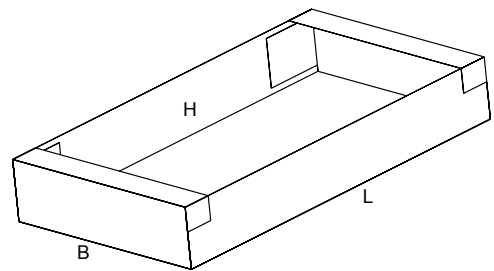
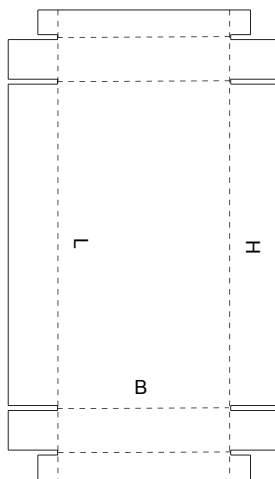

Tabs and slots should conform with the FEFCO Common Footprint standard ([www.fefco.org](http://www.fefco.org)).  
The CF stamp can be downloaded from the FEFCO website.



# 0500

▲ **Slide-type boxes** consist of several pieces of liners and sleeves sliding in different directions into each other. This group also includes outside sleeves for other cases.

▲ **Boîtes coulissantes** constituées par plusieurs manchons coulissants rentrant en différentes directions les uns dans les autres. Ce groupe comprend aussi les manchons extérieurs pour d'autres caisses.

▲ **Schiebeschachteln (Gürtelschachteln)** bestehen aus mehreren in verschiedenen Richtungen ineinanderschließbaren Ringeinsätzen und Manschetten. Zu dieser Gruppe gehören auch Überschiebhülsen.

▲ **Scatole scorrevoli:** Contenitori telescopico composti da diversi pezzi che scorrono l'uno con l'altro. In questo gruppo sono incluse anche le fasce esterne per scatole.

▲ **Cajas de tipo deslizante:** constan de varias piezas de forros interiores y fundas que deslizan en diferentes direcciones uno dentro de otro. Este grupo incluye también fundas exteriores para otras cajas.

## 0501 M

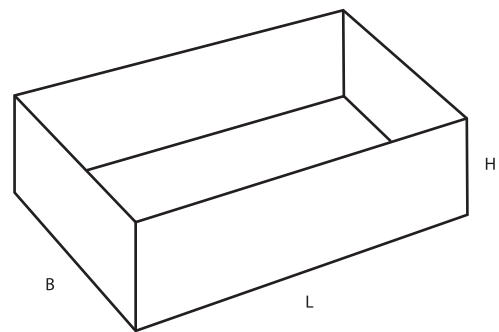
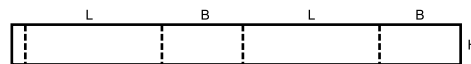

## 0502 M

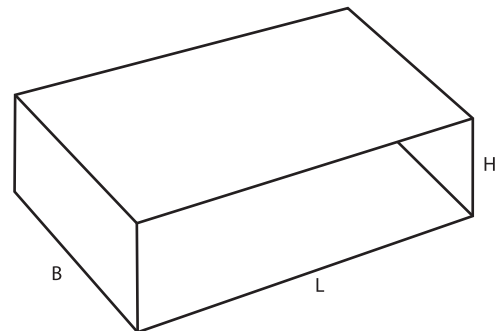
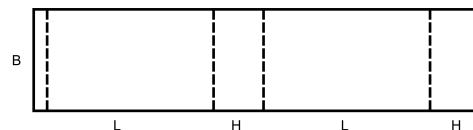

## 0503 M

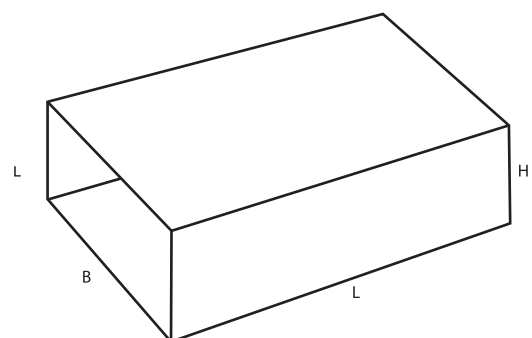
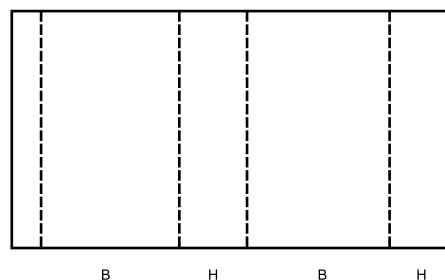

**0504 M**

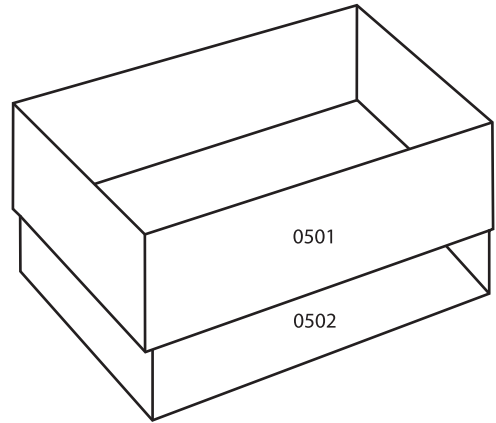
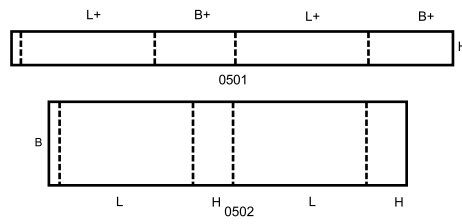

**0505 M**

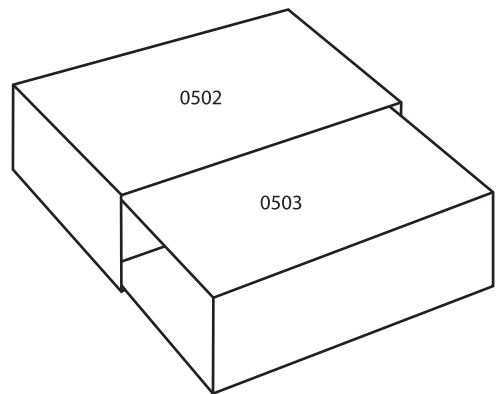
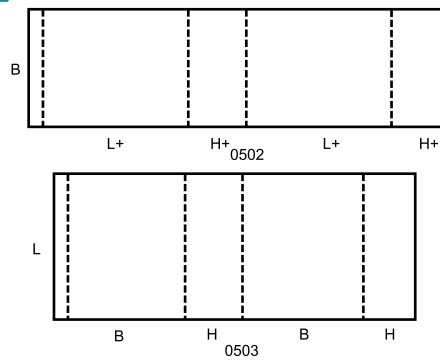

**0507 M**

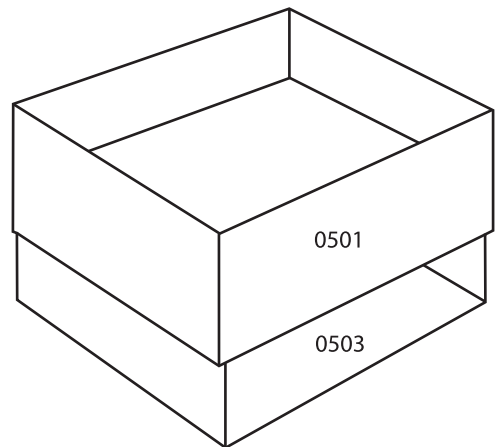
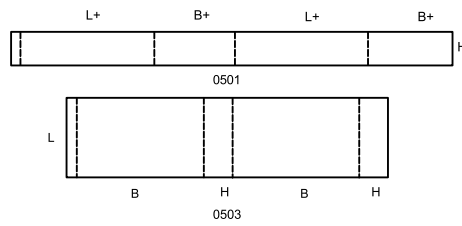

**0509 M**

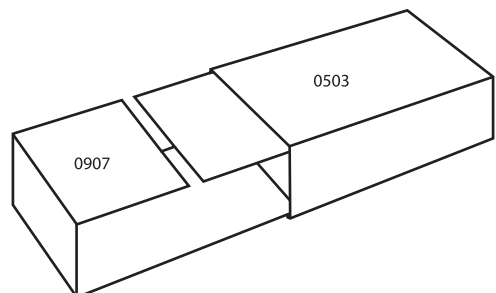
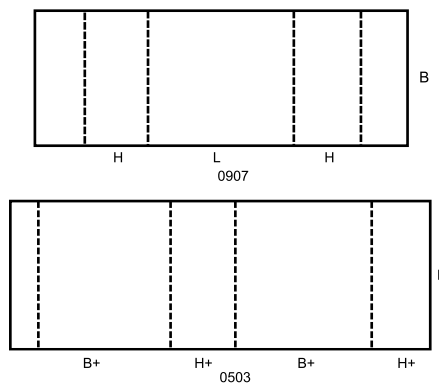

**0510 M**

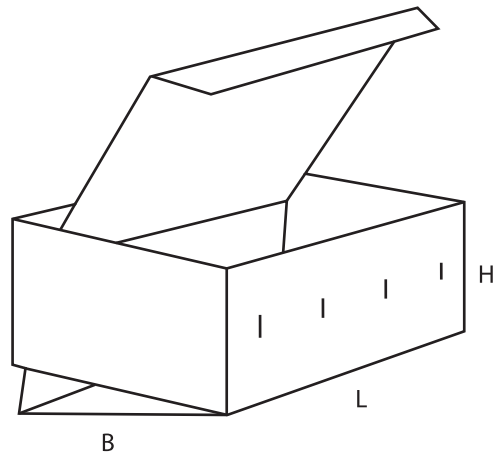
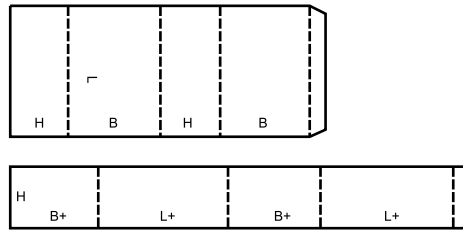

**0511 M**

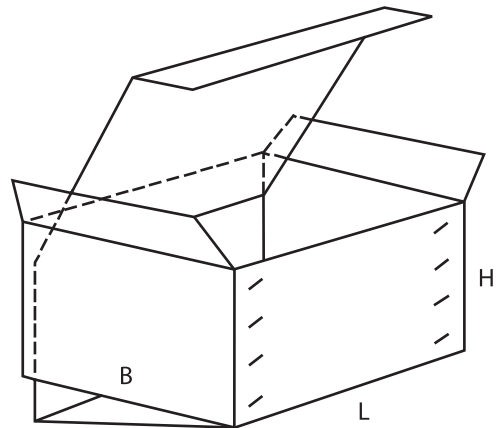
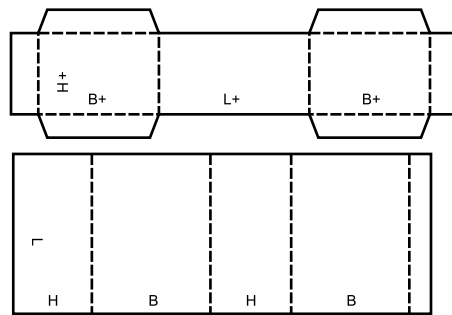

**0512 M**

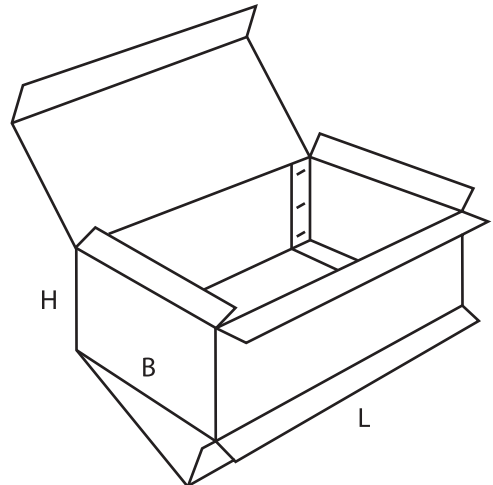
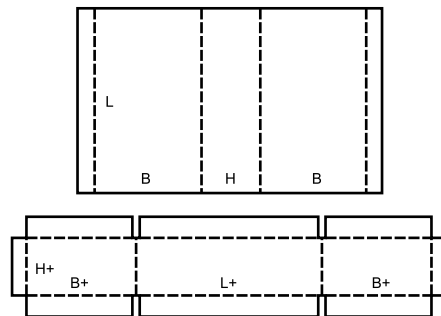

# 0600

▲ **Rigid-type boxes** consist of two separate end pieces and a body and require stitching or a similar operation before they can be used.

▲ **Caisses rigides** constituées de plusieurs pièces nécessitant un assemblage avant emploi.

▲ **Formfeste Schachteln** bestehen in der Regel aus zwei Seitenteilen und einem Mittelteil, das Boden und Dekkel bildet. Diese Schachteln können als vorbereitete Zuschnitte geliefert werden und sind dann vom Verbraucher durch Drahtheftung zu verbinden.

▲ **Casse rigide:** Imballaggi rigidi composti da due pezzi laterali separati e un corpo, e richiedono una fase di cucitura o altro prima di essere utilizzati.

▲ **Cajas de tipo rígidas:** formadas por dos piezas separadas, para los extremos y un cuerpo; requieren un grapado u otra operación similar antes de que puedan utilizarse.

## 0601 A

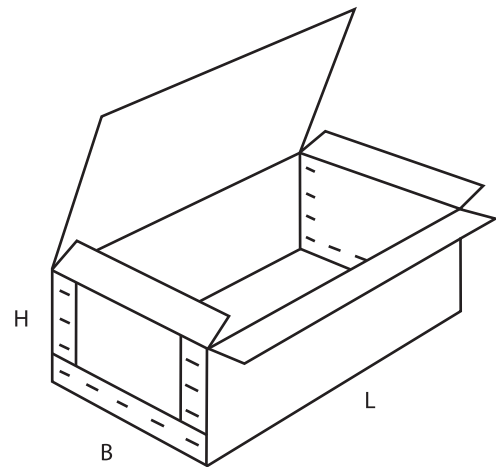
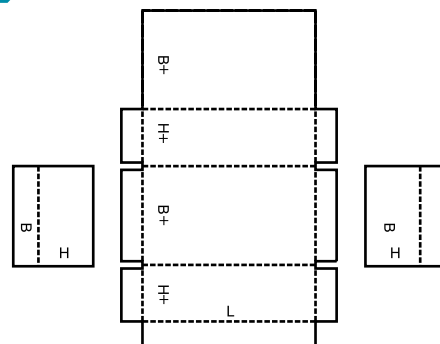

## 0602 A

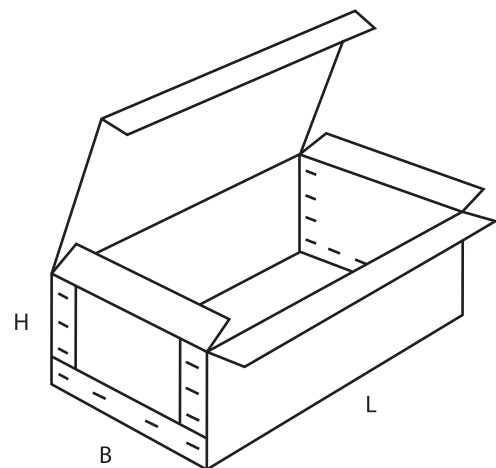
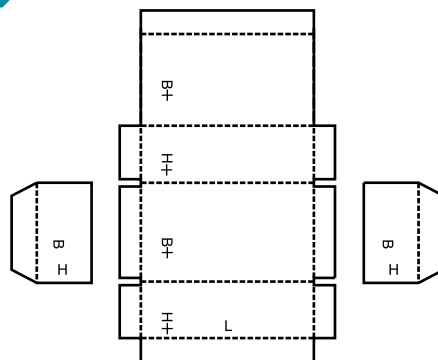

## 0605 A

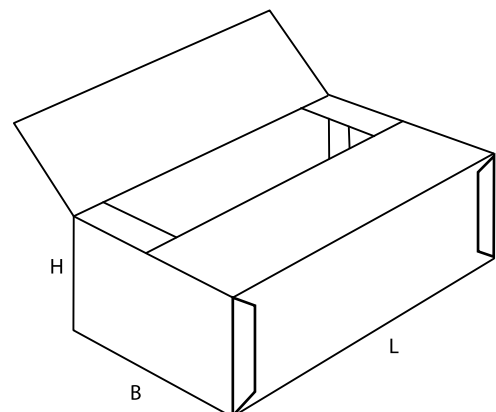
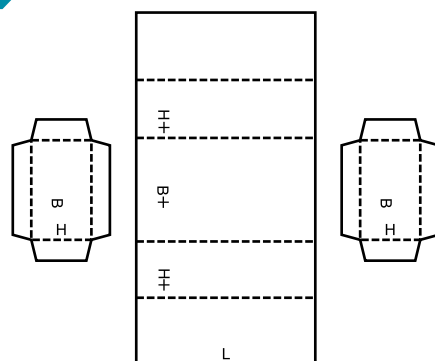

**0606 A**

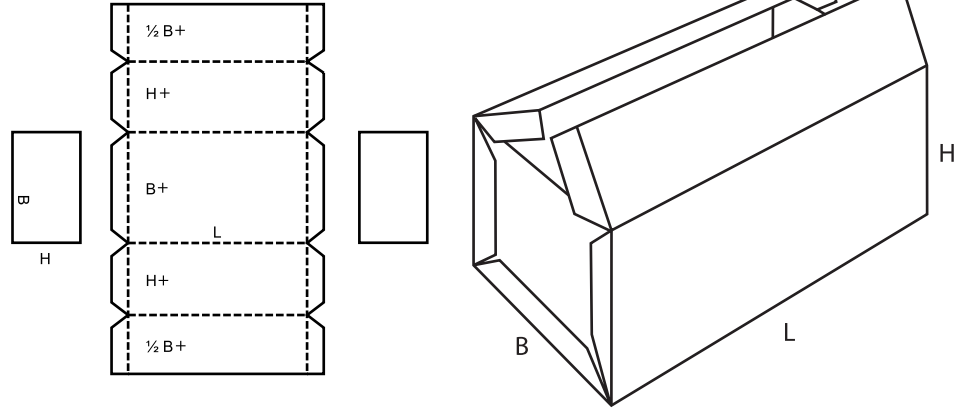

**0607 A**

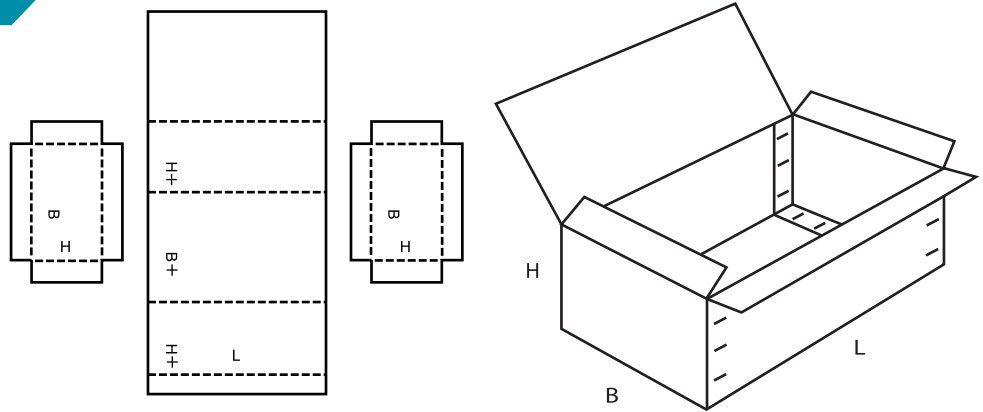

**0608 A**

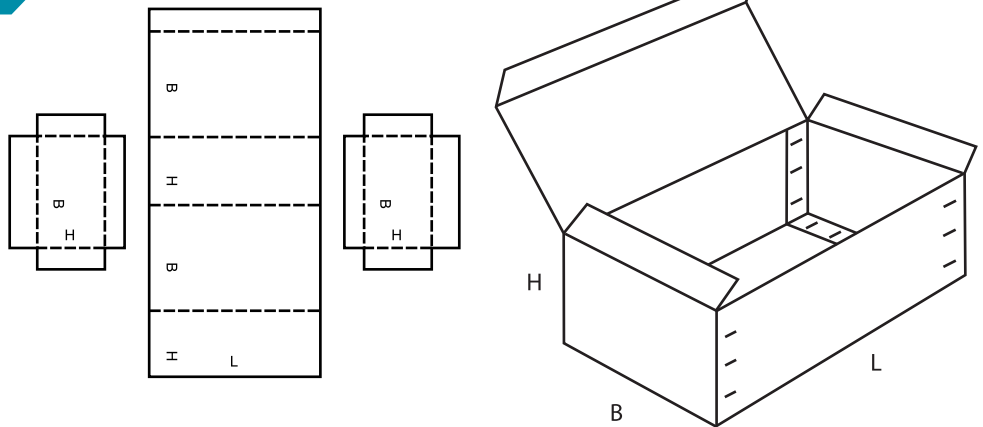

**0610 M/A**

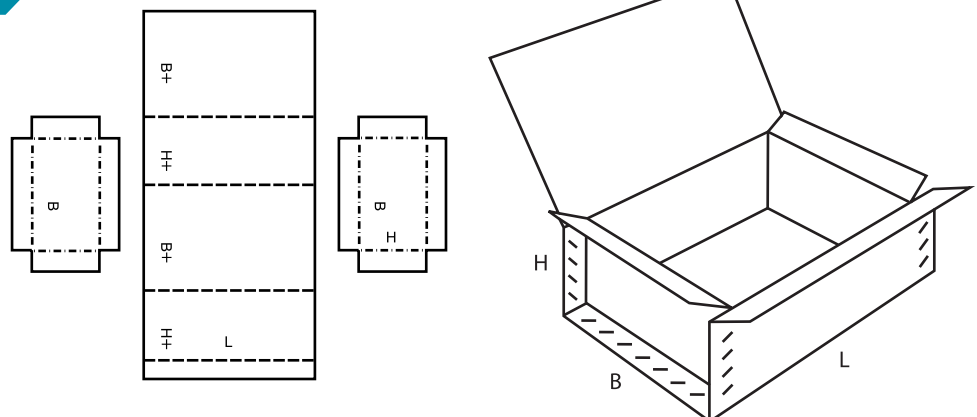

**0615 M/A**

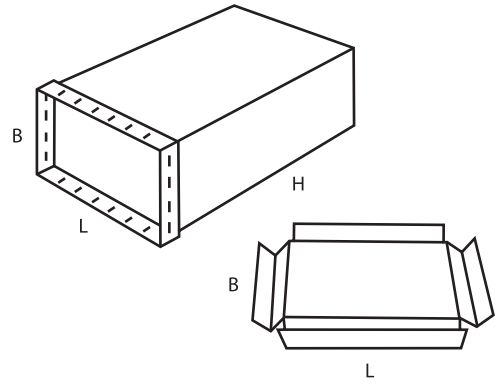
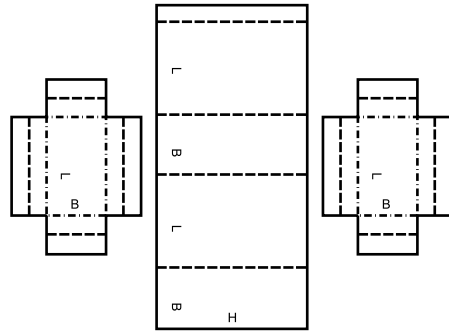

**0616 M/A**

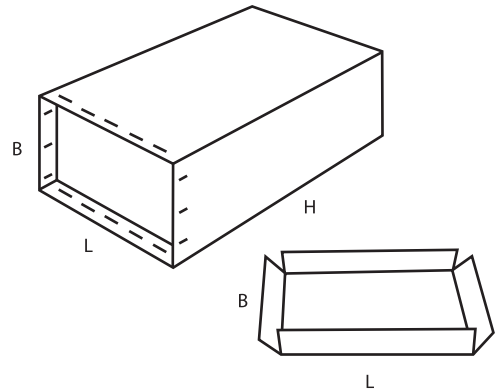
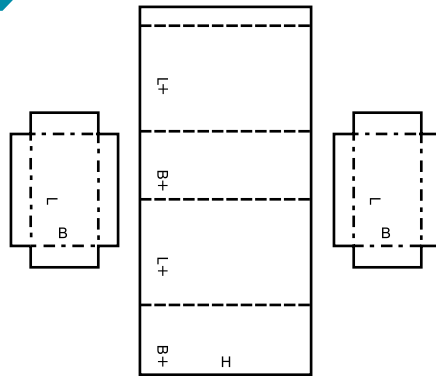

**0620 A**

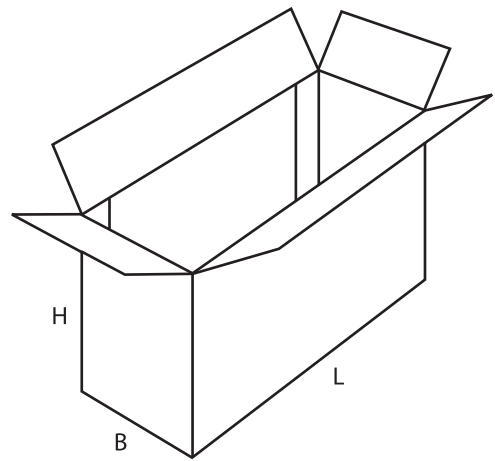
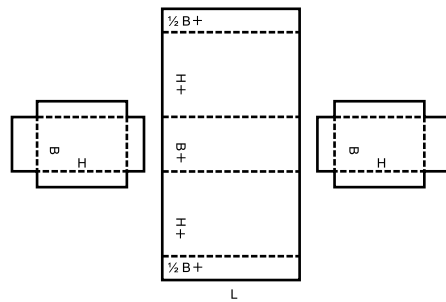

**0621 M**

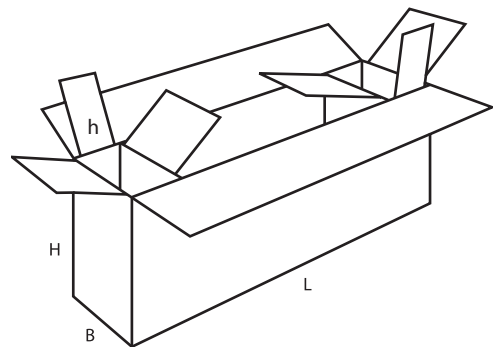
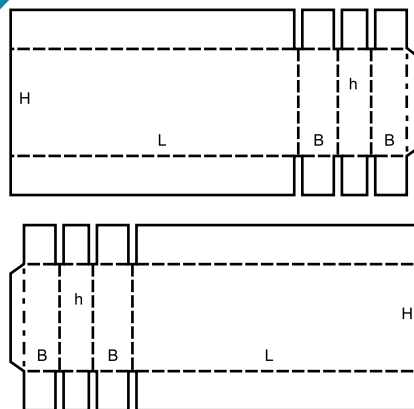

# 0700

- ▲ **Ready-glued** cases consist of basically one piece, are shipped flat and ready to use by simple setting up.
- ▲ **Caisses collées** prêtes à l'emploi, constituées en principe par une seule pièce, livrées à plat et prêtes à l'emploi après un simple montage.
- ▲ **Fertig geklebte** Schachteln sind einteilige, faltbare Schachteln, die zusammengelegt geliefert und durch einfaches Aufrichten gebrauchsfertig aufgestellt werden. Die Schachteln können mit einem Faldboden (Faldbodenschachtel) oder mit Diagonalbiegung (Aufrichteschachtel) ausgerüstet sein.

- ▲ **Casse incollate e pronte all'uso:** Imballaggi incollati già pronti composti in genere da un pezzo, sono consegnati piegati e sono pronti per l'uso tramite una semplice fase di montaggio apertura.
- ▲ **Cajas de encolado rápido:** están hechas generalmente de una sola pieza, se entregan extendidas en un plano o plegadas y listas para su utilización por medio de un sencillo montaje.

## 0700 M

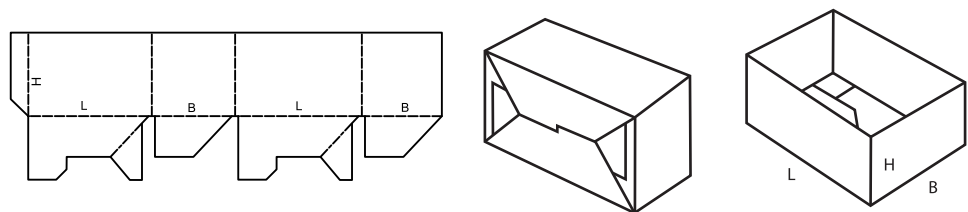

## 0701 M

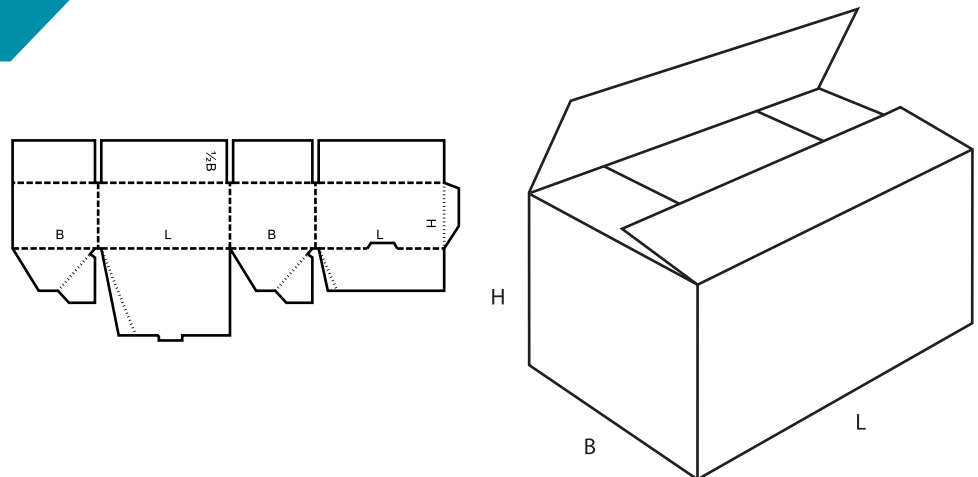

## 0703 M

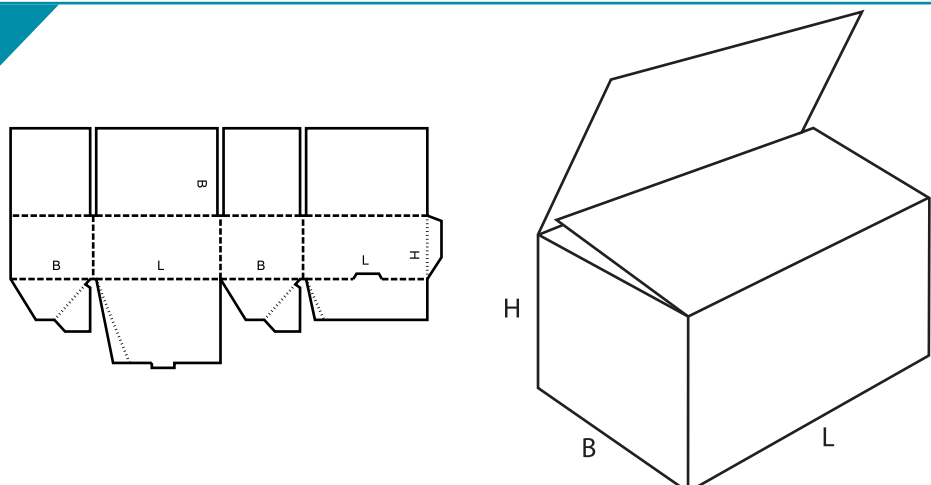

0711

M

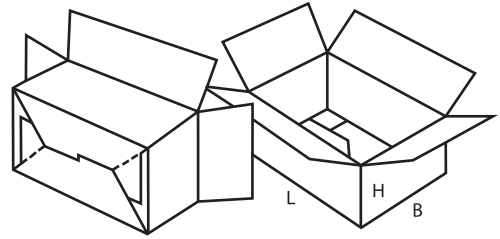
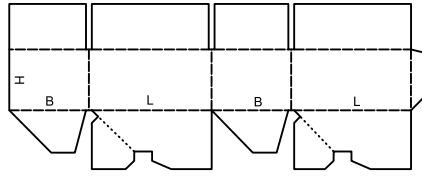

0712

M

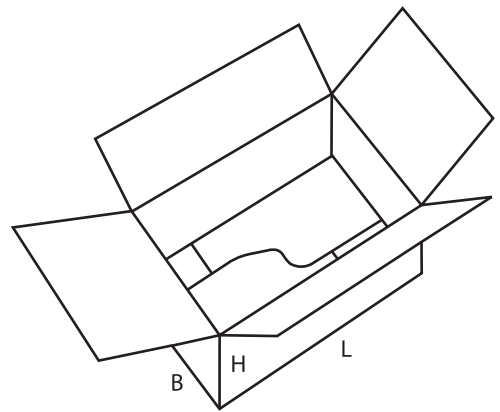
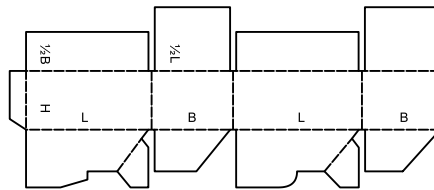

0713

M

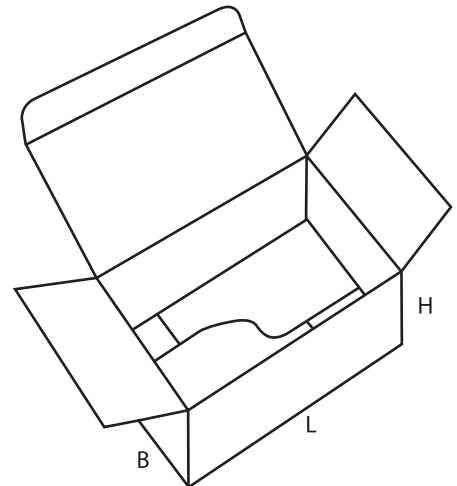
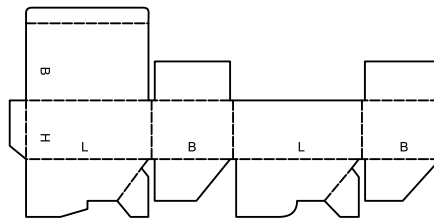

0714

M

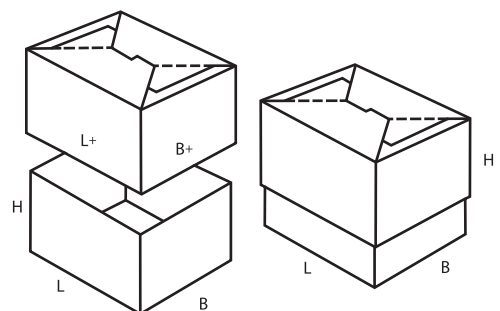
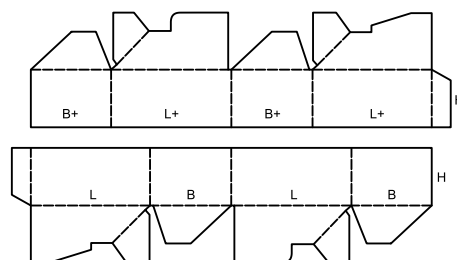

**0715** M

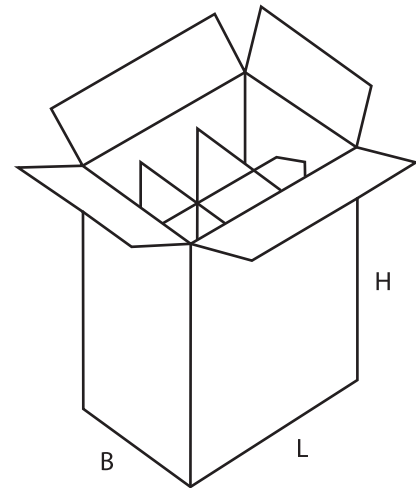
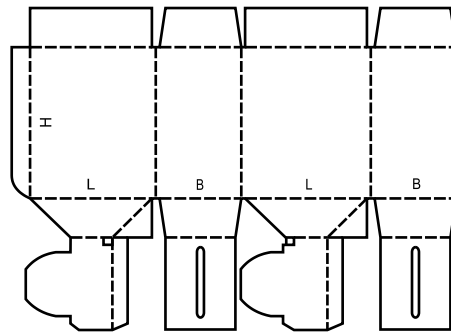

**0716** M

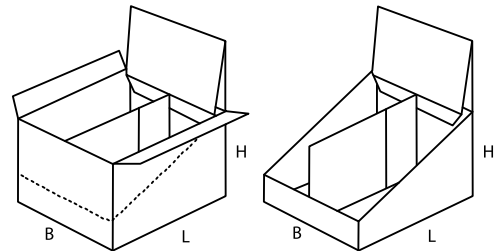
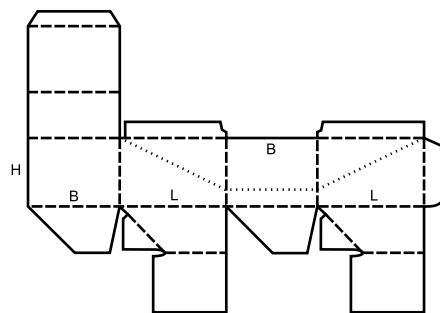

**0717** M

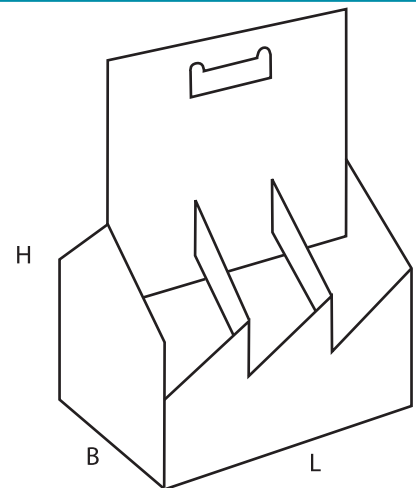
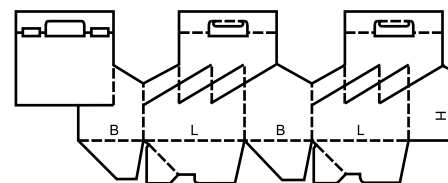

**0718** M

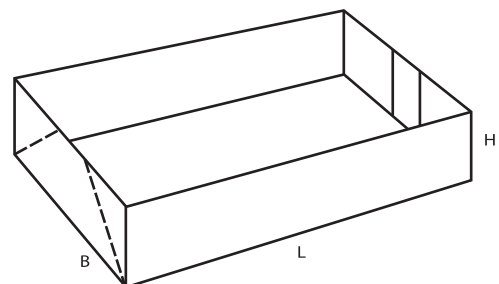
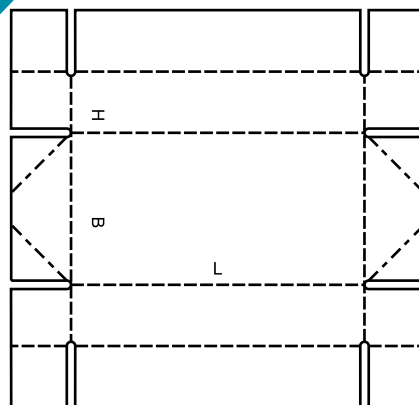

$B \geq 2H$

**0747** M

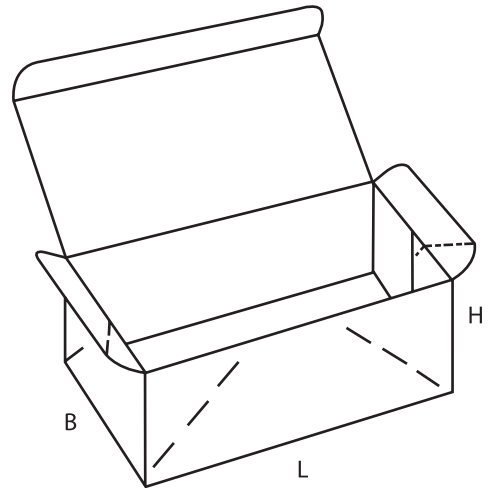
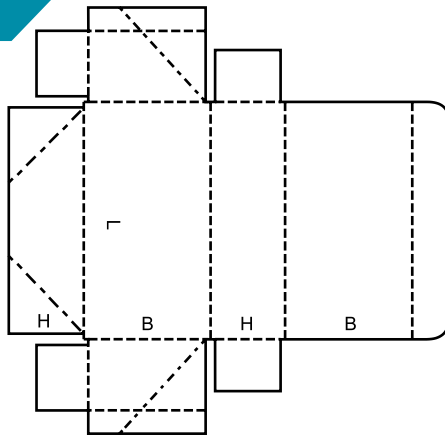

**0748** M

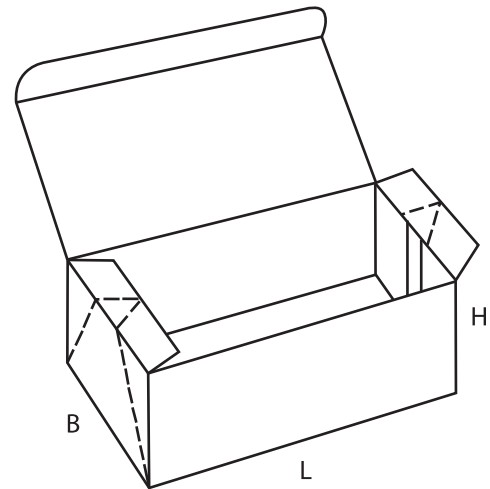
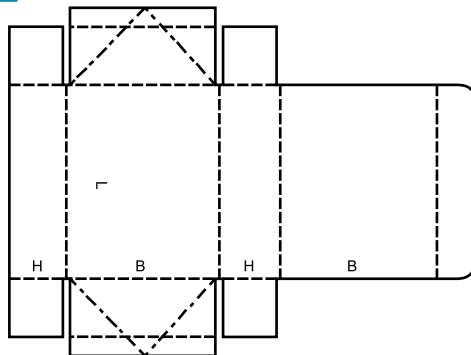

**0751** M

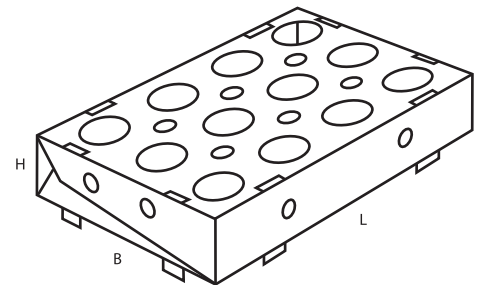
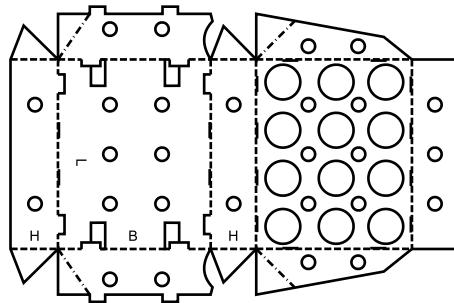

**0752** M/A

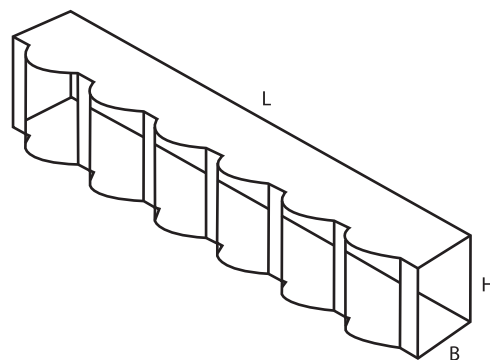
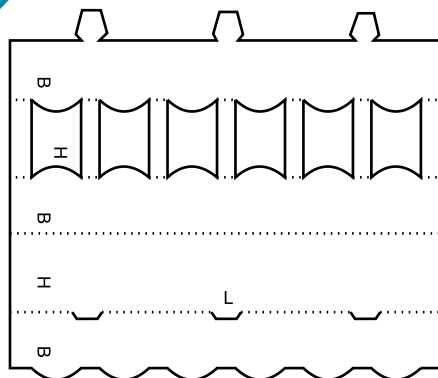

**0759 M**

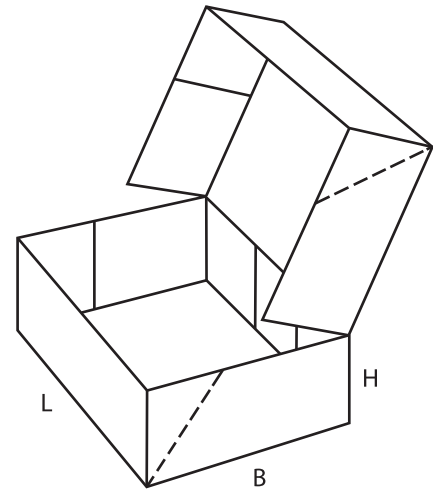
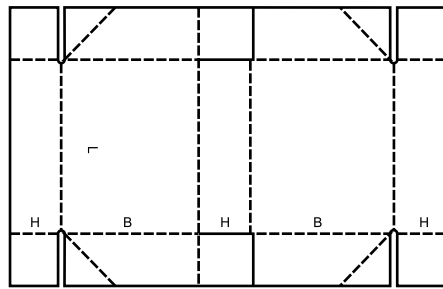

**0761 M**

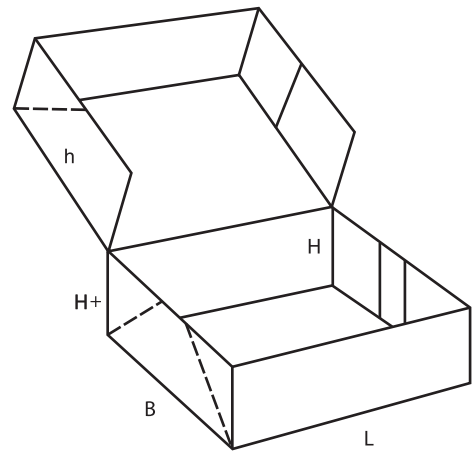
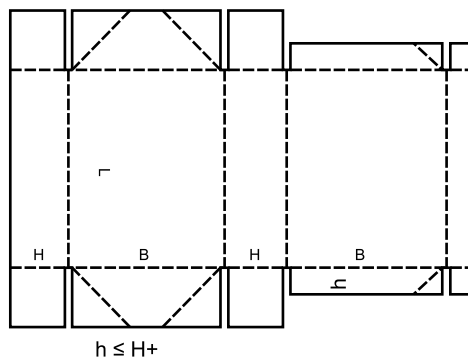

**0770 M**

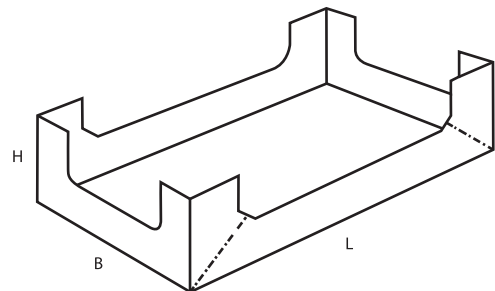
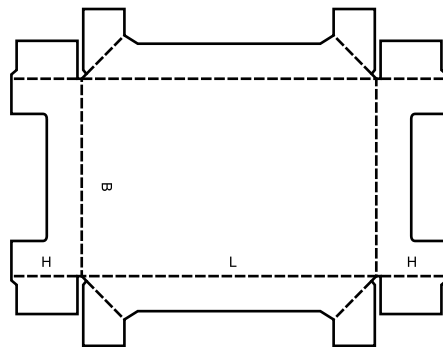

**0771 M**

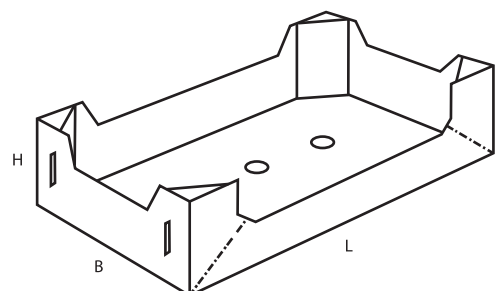
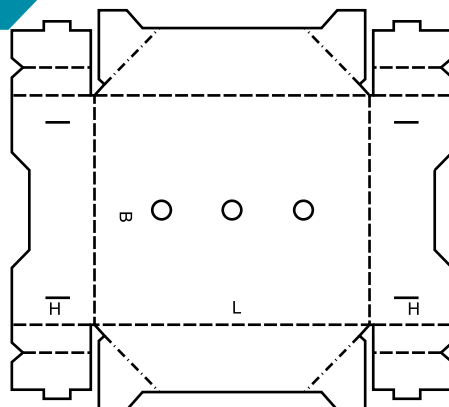

**0772** M

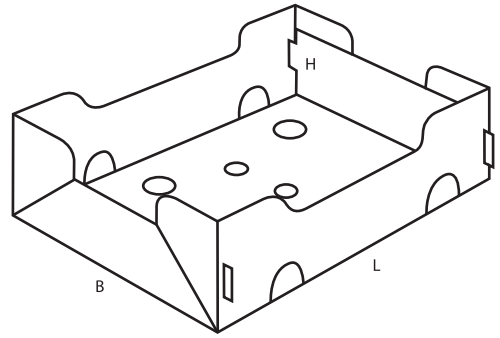
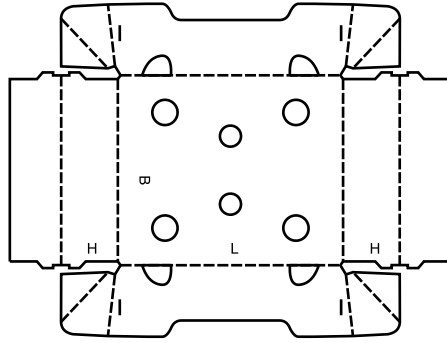

**0773** M

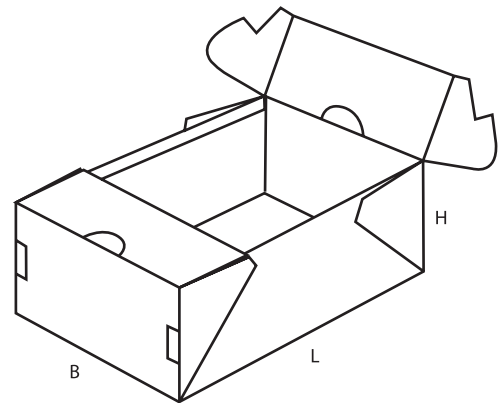
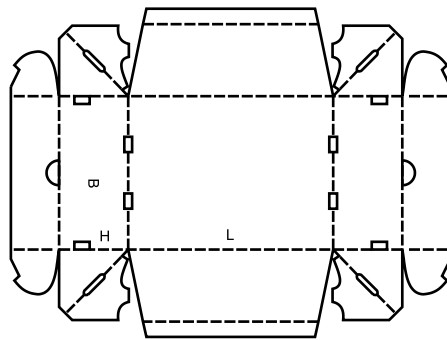

**0774** M

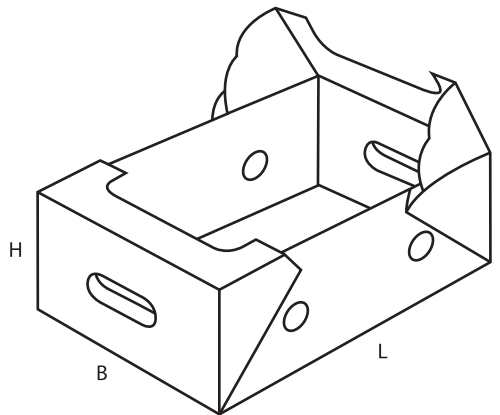
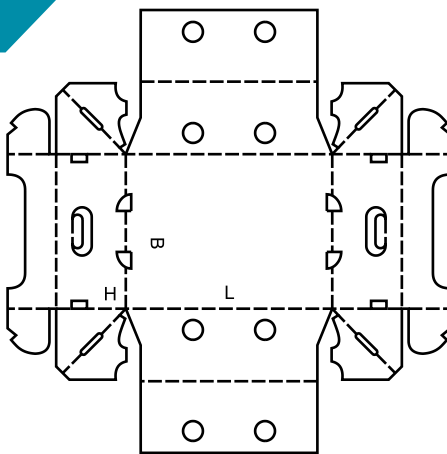

# 0900

- ▲ **Interior fitments** such as inside liners, pads, partitions, dividers etc., whether tied to Case Design or as singular items. Any shown number of panels is arbitrary and may be increased or decreased as required.
- ▲ **Conditionnement intérieur**, tel que doublures intérieures, rembourrages, casiers, cloisons, etc ... , faisant partie du modèle de caisse ou utilisés comme éléments indépendants. Tout nombre de panneaux indiqué est arbitraire et pourra être augmenté ou diminué selon les besoins.
- ▲ **Inneneinrichtungen** wie Einlagen, Einsätze, Stege, Trennwände, Gefache, Polster und dgl., ob mit der Kiste fest verbunden oder als getrennte Elemente.

Zahlenangaben für Wände sind beliebig und können ggf. höher oder niedriger ausfallen.

- ▲ **Protezioni interne:** Pezzi interni come fodere interne, imbottiture, separatori, divisori ecc., sia come accessori ad un imballaggio, sia come articoli a se stanti. I numeri di pannelli che compaiono nei disegni sono arbitrari e possono essere diminuiti o aumentati secondo le esigenze.
- ▲ **Acondicionadores interiores:** como forros, refuerzos, casilleros, divisiones interiores, tanto si se ajustan a un modelo de caja o como piezas sueltas. El número de piezas de los acondicionadores interiores mostrados es arbitrario y puede aumentarse o disminuirse de acuerdo con las necesidades.

## 0900 M

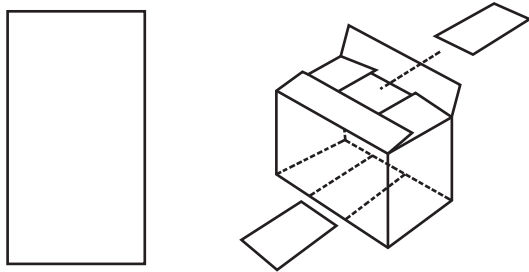

## 0901 M

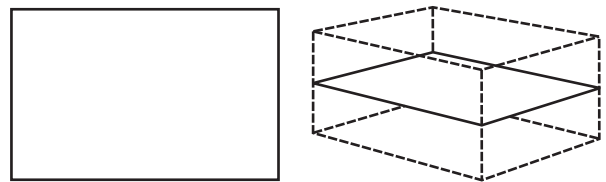

## 0902 M

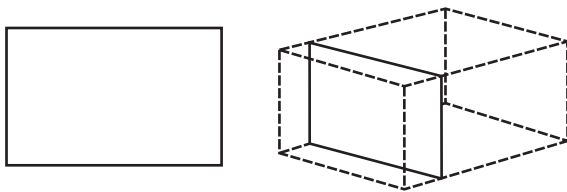

## 0903 M

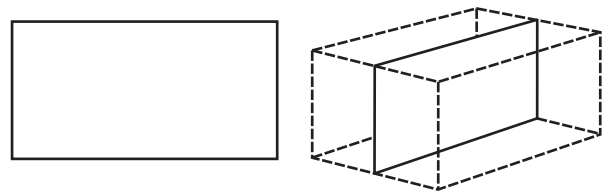

## 0904 M

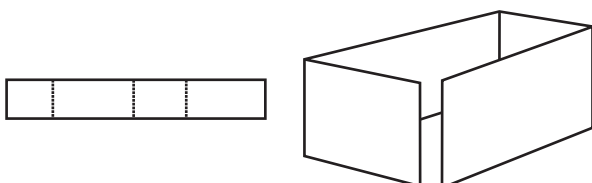

## 0905 M

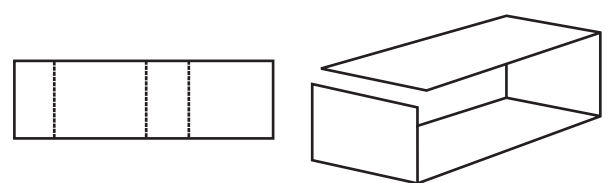

**0906 M**

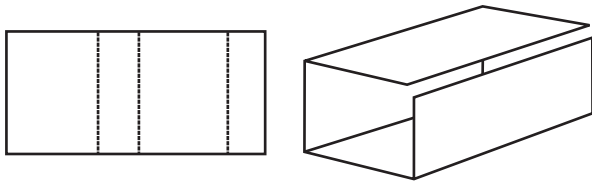

**0907 M**

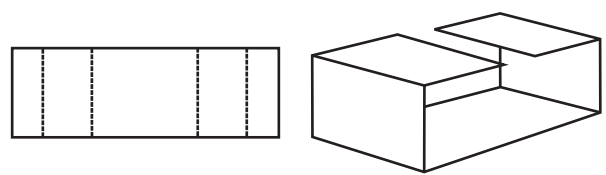

**0908 M**

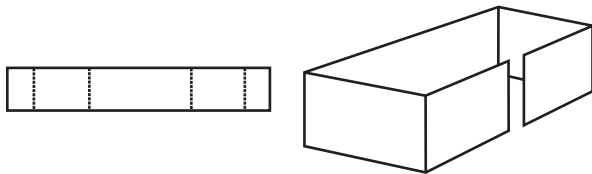

**0909 M**

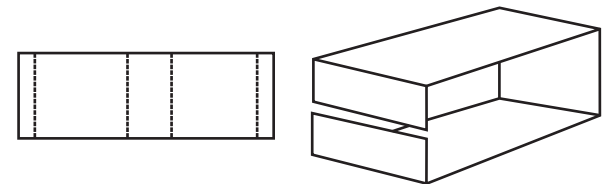

**0910 M**

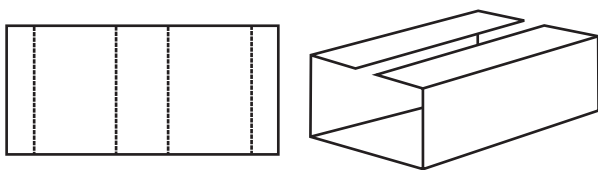

**0911 M**

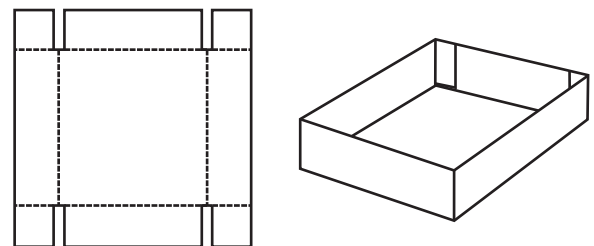

**0913 M**

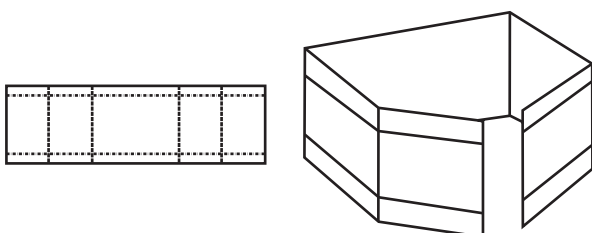

**0914 M**

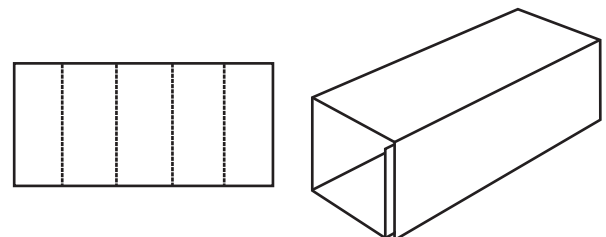

**0920 M**

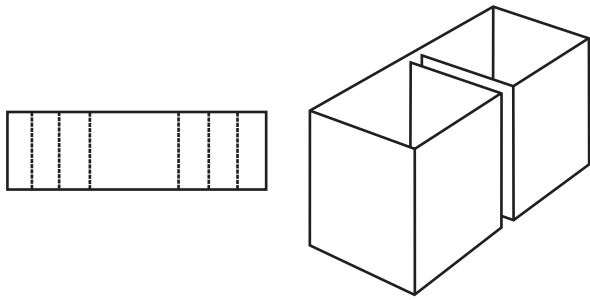

**0921 M**

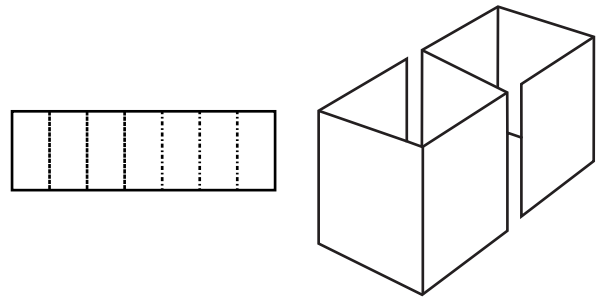

**0929 M**

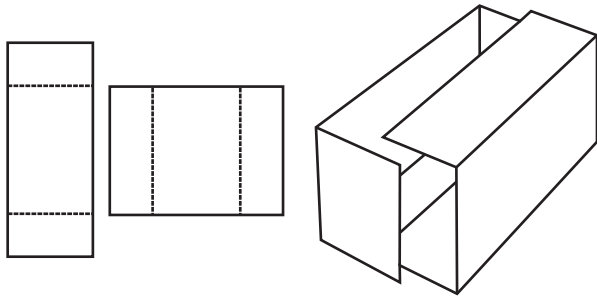

**0930 M**

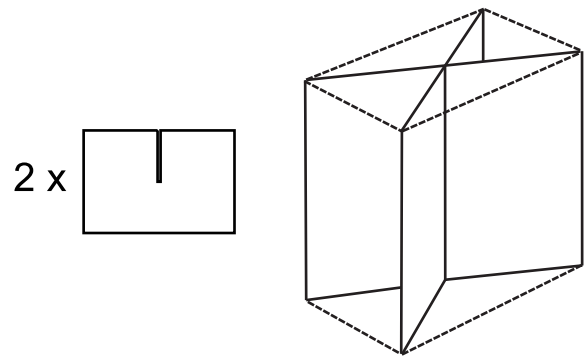

**0931 M**

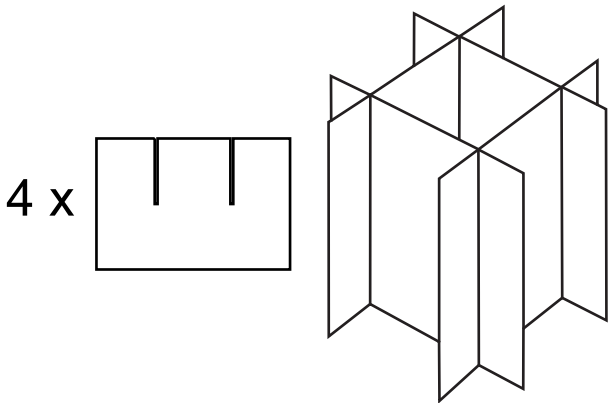

**0932 M**

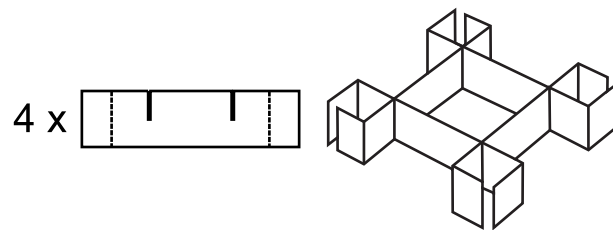

**0933 M**

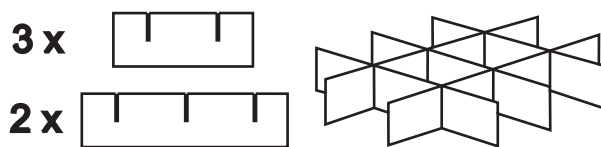

**0934 M**

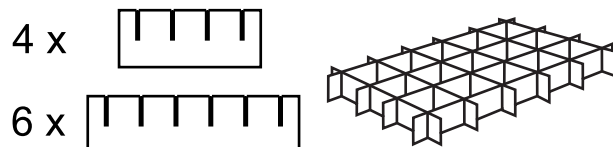

0935 M

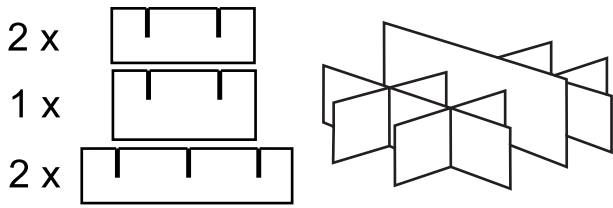

0940 M

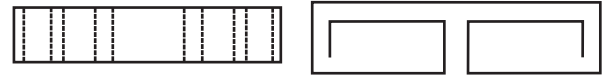

0941 M



0942 M

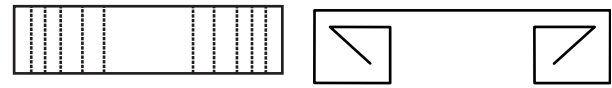

0943 M



0944 M



0945 M



0946 M



0947 M



0948 M

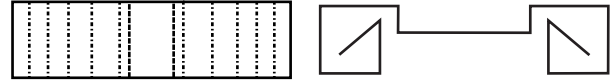

0949 M

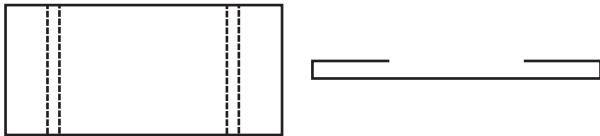

0950 M

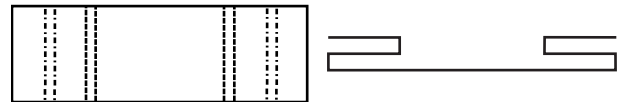

0951 M

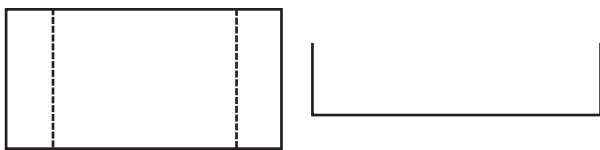

0965 M

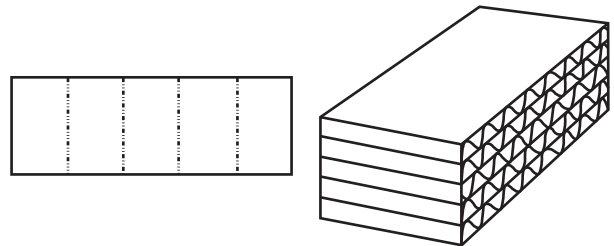

0966 M

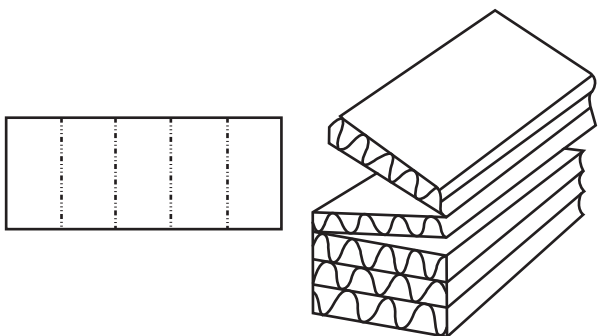

0967 M

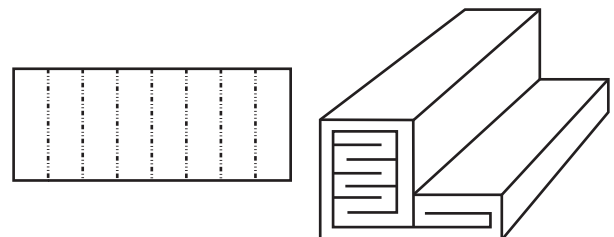

0970 M

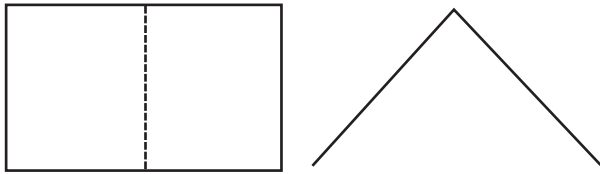

0971 M

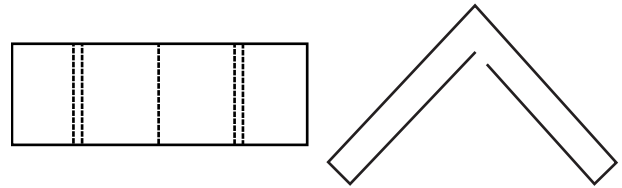

0972 M

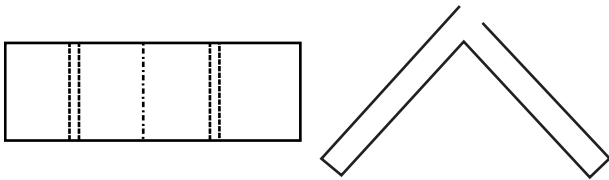

0973 M

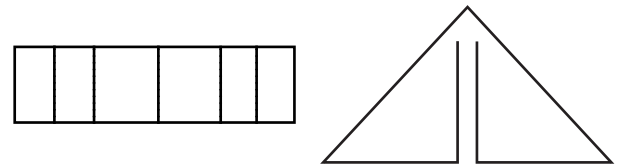

0974 M

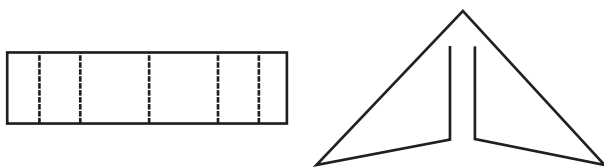

0975 M

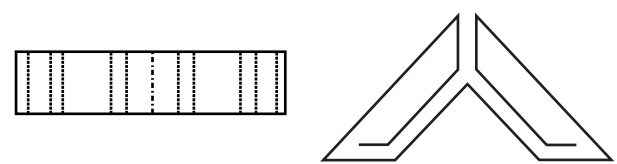

0976 M

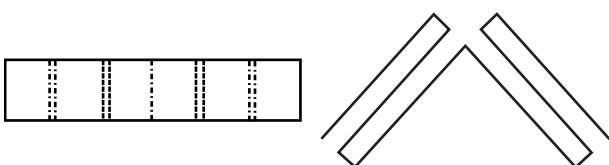

# FEFCO

Corrugated Packaging

250 avenue Louise 1050 Brussels  
Tel: +32 2 646 4070  
Fax: +32 2 646 6460  
E-mail: [info@fefco.org](mailto:info@fefco.org)  
Twitter @FEFCO

[www.fefco.org](http://www.fefco.org)

Member of

**citpa**

**ICA**